

FOR TRON PROGRAMING CONTEST APPLICANTS

INTRODUCTION RA4E1/RA8P1 FOR EDGE AI

24/6/2026
RENESAS ELECTRONICS
EP/EPMAJ

AGENDA





- Renesas MCU overview
- RA4E1 Feather
- What edge AI?
- RA8P1 Feather
- Tool for AI Application
- Summary

RENESAS MCU STRATEGY



RENESAS MCU/MPU OVERVIEW

- (1) With our extensive product lineup, we provide devices tailored to our customers' needs.
 (2) We contribute to our customers' businesses in a scalable manner through standardized drivers, software, development environments, tools, and more.

8/16-bit MCU		32-bit MCU			32/64-bit MPU
Renesas Core		Arm® Core / RISC-V® Core			
					
Low Power	Power Efficiency	Arm® Ecosystem	Open ISA	High Performance	
Features : <ul style="list-style-type: none"> • Ultra Low power • Small pin lineup MAX Frequency : 20~48MHz	Features : <ul style="list-style-type: none"> • High performance • Scalable • Large Flash memory • Wide lineup • Security MAX Frequency : 32~240MHz	Features : <ul style="list-style-type: none"> • High performance • Scalable • Large Flash memory • Wide lineup • Security • Dual CPU MAX Frequency : 32~1GHz	Features : <ul style="list-style-type: none"> • In-house RISC-V Core • Low consumption ASSP <ul style="list-style-type: none"> • Andess RISC-V 32bit CPU Core • Motor control/Voice recognition turnkey MAX Frequency : 32~100MHz	Features : <ul style="list-style-type: none"> • Multi core • Linux or RTOS • Large RAM and DDR integrate • HMI • AI program • Industry multi network MAX Frequency : 125MHz~1.8GHz	

RENESAS RA FAMILY SERIES LINE-UP

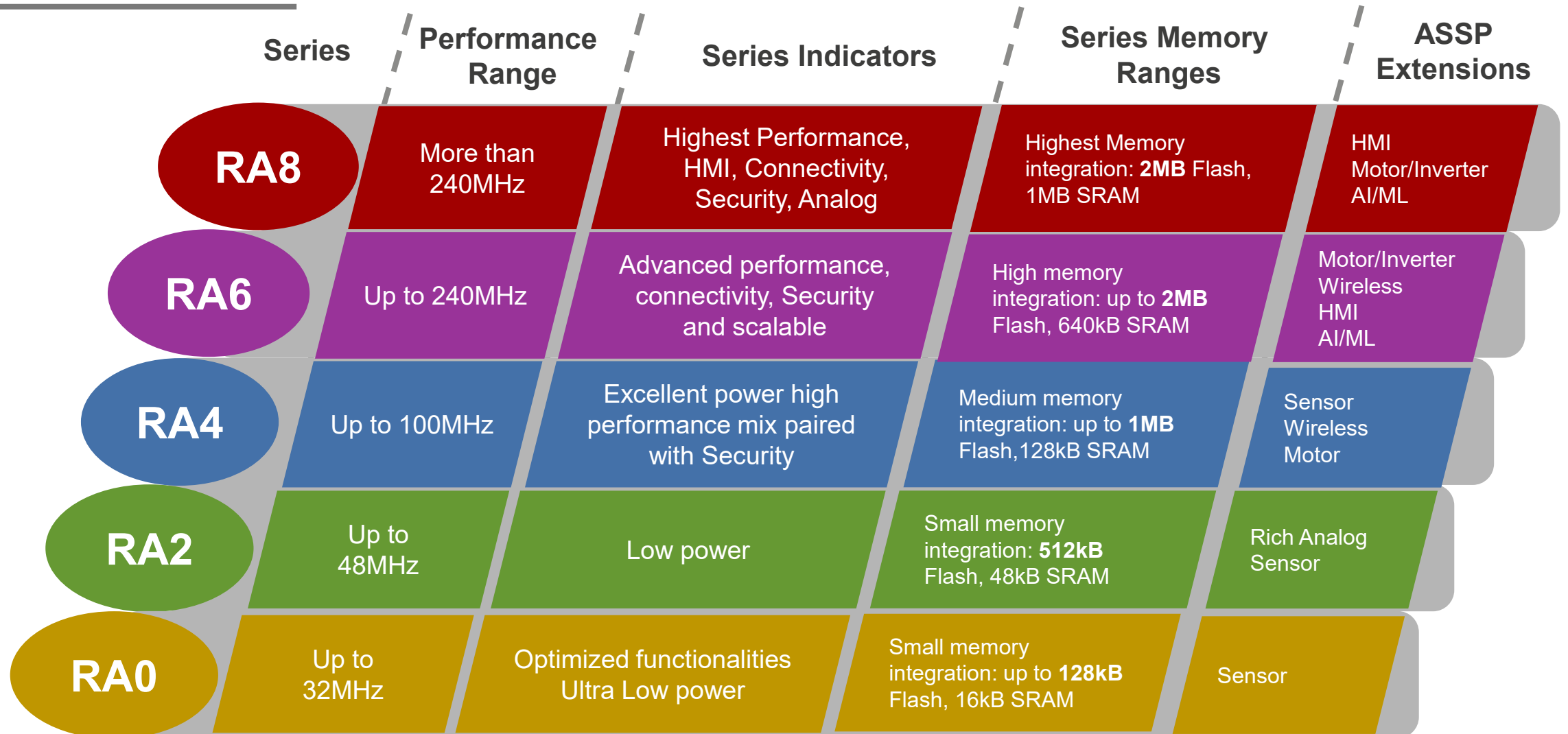

RA4E1 FEATURES



FEATURES OF RA4 ENTRY LINE

The Entry Line of the RA4 series has the following features.

Feature-optimized Arm CM33 MCU

- Pursues optimization of functionality and cost, yet achieves the same performance as mainstream
Operating frequency: 100MHz(RA4)
- Expanding lineup of memory, low-pin count and small packages to meet a variety of cost- and space-constrained applications
- Supports a wide range of communication interfaces to meet emerging market needs

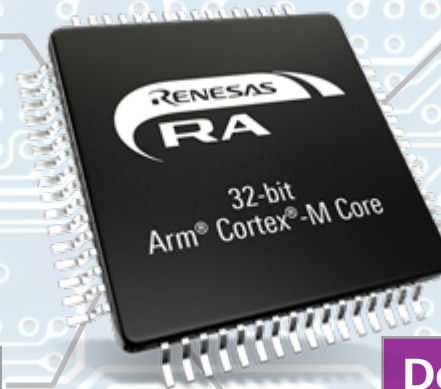

Wide variety of memory and package lineups

- 128KB ~ 1MB High-speed Flash memory
- Data Flash to store data as in EEPROM
- Up to 256KB SRAM (ECC/parity)
- Stand-by SRAM
- External memory interface
- 32-pin ~ 100-pin, LQFP, QFN, BGA package
Series smallest 4x4 mm 36-pin BGA

Various proven peripheral functions

- Various communication functions such as Ethernet, USBFS, CANFD, I3C, SSI, HDMI CEC
- Various Timers
- ADC, DAC
- High-precision on-chip oscillator
- Peripheral functions unique to Renesas MCUs such as DTC and ELC

Development environment and ecosystem to support development

- Free, high-quality Flexible Software Package
- Supports various Renesas/partner development environments
- Rich solutions from ecosystem partners
- Ideal product group as a starting point for the RA Family due to functional compatibility with mainstream and shared FSP

RA4E1

100MHZ ARM CORTEX M33 LOW POWER AND OPTIMIZED FEATURE SET



Samples	NOW
Production	NOW

Features

- 100MHz Arm® Cortex®-M33 with 512KB Flash Memory and 128KB SRAM
- 8KB Data Flash to store data as in EEPROM and 1KB Stand-by SRAM
- Available in 48pin QFN and 64pin LQFP Package options
- USB2.0 Full Speed, CAN 2.0B
- SCI (UART, Simple SPI, Simple I2C), SPI/ I2C Multi-master interface
- QSPI, SD/MMC interface, SSI
- Integrated ADC and DAC units
- TRNG and Unique ID
- Available on Fast Prototyping Board (FPB), and AI and Voice Reference Kits

Benefits

- Optimized mixture of high performance with 100 MHz Cortex-M33 Core in combination with lowest active power consumption.
- Value optimized feature with analog and connectivity integration
- Wide temperature range
- Easy migration to Mainstream-line and ASSP products with FSP and HW compatibility

Typical Applications

- AI/ML Applications ([Edge Voice User Interface](#))
- Home Appliances ([Smart Coffee Machine](#))
- Smart Home and Building ([Smart IoT Air Purifier](#))

Block Diagram

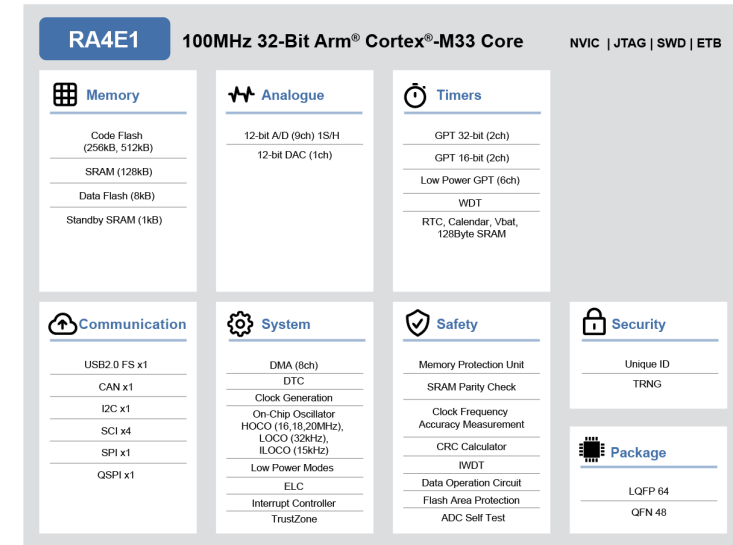

Example Application (Voice User Reference Kit)

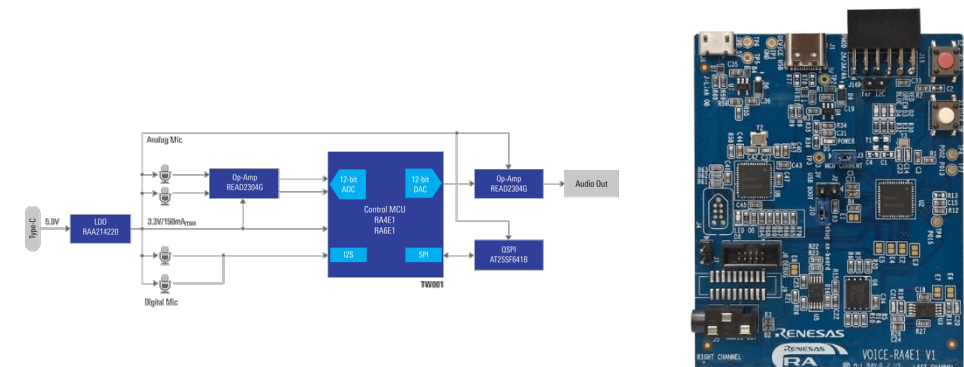

FPB-RA4E1

FAST PROTOTYPING BOARD FOR RA4E1 MCU GROUP

Key Features

MCU Native Pin Access

- R7FA4E10D2CFM MCU
- 100 MHz, Arm Cortex®-M33 core
- 512 KB Code Flash, 128 KB SRAM
- 64-pin LQFP package
- Native pin access through male pin headers
- MCU current measurement points

Ecosystem & System Control Access

- 5 V input through USB (Debug) or external power supply
- Debug on-board (Segger J-Link®)
- 2 User LEDs & 1 User button
- 2 Digilent Pmod™ (SPI & UART)
- Arduino™ (Uno R3)
- MCU boot configuration jumper

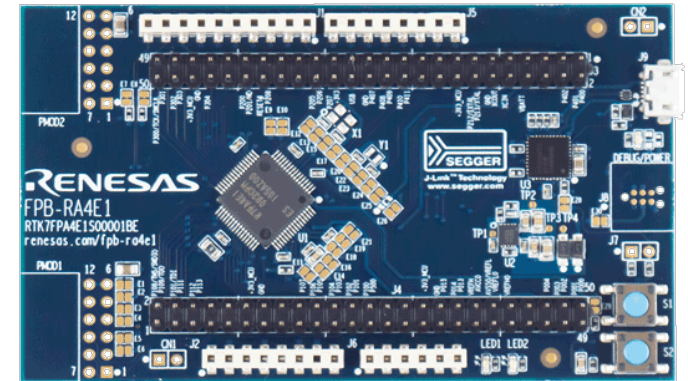

renesas.com/ra/fpb-ra4e1

(User manual, quick start guide, development tools, schematics, design files & example projects)

RTK7FPA4E1S00001BE

(Orderable part number)



WHAT IS EDGE AI ?



AI AT THE EDGE – A PARADIGM SHIFT

Cloud AI – Inference in the cloud

IDC estimates that there will be 79.4ZB of data created by connected IoT devices by 2025

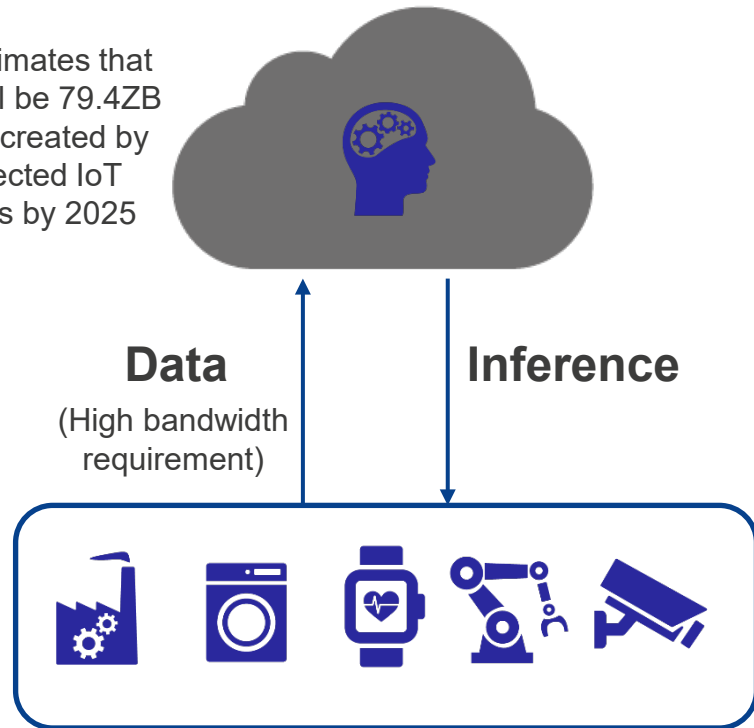

Edge AI – Inference on Edge device

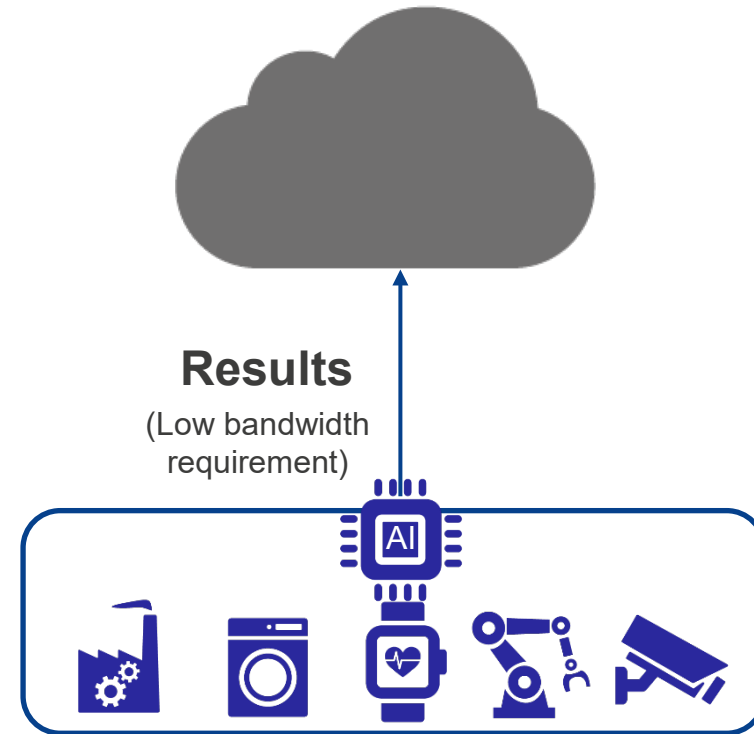
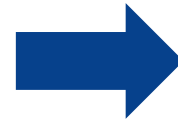

Why AI at the edge

- ✓ Fast, real-time responses without the latency of a cloud connection
- ✓ Lower power consumption
- ✓ Higher security and privacy
- ✓ Lower costs of cloud connectivity

Edge AI enables autonomy, lower latency, lower power, lower bandwidth needs, lower costs and higher security

RA8P1 CONTRIBUTES TO EDGE AI

- Featuring an industry-leading 1GHz Arm Cortex[®]-M85 and the dedicated AI accelerator Arm Ethos[™]-U55
- Includes peripheral functions for edge AI applications
- Provides solutions to accelerate edge AI application development

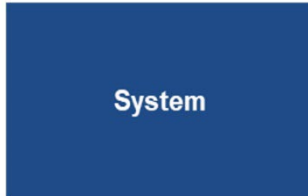
Embedded memories 1MB code MRAM 2MB SRAM 8/4MB Flash (option)	Arm Cortex-M85 Up to 1GHz	Arm Ethos-U55 256MACs/c 
External memory IF OSPI (XIP&DOTF) External 32bit Bus		
Camera & Audio MIPI-CSI2 2-lane CEU SSIE x2 PDM 3ch	Arm Cortex-M33 Up to 250MHz	
Graphics GLCDC MIPI-DSI 2D DRW		
	System	Analog
	Security	Timers
		Connectivity

Industry-leading CPU processing performance

- **7300+ CoreMark with Dual CPU cores** (Cortex-M85@1GHz + Cortex-M33@250MHz)

AI-dedicated acceleration

- Arm Ethos[™]-U55 offloads inference processing from the CPU (256 GOPS)

Peripheral functions for HMI suitable for vision/voice AI

- Parallel camera input, MIPI-CSI2, and image preprocessing functions
- Serial sound input and audio input via PDM

Robust security features

Solutions for efficiently advancing AI/ML development

- Easy to use **RUHMI* Framework** (AI compiler)
- **Pre-trained model** will be progressively updated. Provided as application notes.

*Robust Unified Heterogenous Model Integration

RA8P1 FEATURES



RA8P1 FEATURES

1GHZ ARM CORTEX-M85 + 250MHZ ARM CORTEX-M33 CORES, ETHOS-U55 NPU, AI/ML FOCUS

Arm® Cortex-M85 & Cortex-M33 Cores

- >7300 CoreMark, TrustZone on both cores
- Arm v8.1m architecture, Helium/MVE extensions on CM85

Ethos-U55 NPU, Hardware AI Acceleration

- AI performance up to 256 GOPS
- Lower power consumption per inference vs. CPU core

Embedded Memory and Interfaces

- 1MB MRAM and 2MB SRAM
- Multiple memory interfaces – OSPI, SDRAM

Vision and Voice AI Features

- Parallel and MIPI CSI-2 camera interfaces
- I2S and PDM interfaces for voice AI

Graphics capabilities

- GLCDC with parallel RGB and MIPI DSI interfaces
- 2D graphics accelerator

Advanced Security

- Advanced cryptography, Secure boot
- Arm TrustZone, tamper protection

RA8P1

1GHz Arm® Cortex®-M85 Core,
+ 250MHz Arm® Cortex®-M33 Core
Ethos™-U55 NPU

FPU | ARM MPU | NVIC | JTAG |
SWD | ETM | Boundary Scan

<h4>Memory</h4> <ul style="list-style-type: none">Code NVM (MRAM 0.5/1MB, Flash 4/8MB)Data SRAM w/ ECC (1.6MB)TCM (256KB for Cortex-M85 + 128KB for Cortex-M33)I/D-Cache (32KB for Cortex-M85 + 32KB for Cortex-M33)	<h4>Analog</h4> <ul style="list-style-type: none">16-bit ADC (2units, 23ch, 3ch-S/H x2)12-bit DAC (2ch)High-speed Comparator (4ch)Temperature Sensor	<h4>Timers</h4> <ul style="list-style-type: none">32-bit GPTE (High Resolution) (4ch)32-bit GPTE (10ch)32-bit ULPT (2ch)16-bit AGT (2ch)WDT (2ch)RTC	<h4>HMI</h4> <ul style="list-style-type: none">Graphics LCDC w/ RGB i/f2D DRWMIPI DSI MIPI CSI-2CEU 16bit Camera Interface
<h4>Communication</h4> <ul style="list-style-type: none">Gigabit Ethernet MAC w/ TSN (x2) + 2 port switchCAN-FD (x2)USB2.0 FS (x1), USBHS (x1)SDHI/MMC (x2)I3C (x1), I2C (x3)SCI (x10)SPI (x2)OSPI (x2, XIP&DOTF)SSI x2 & PDM 3ch x132-bit External Memory Bus	<h4>System</h4> <ul style="list-style-type: none">DMA (8ch x2)DTC (x2)Clock GenerationOn-chip OscillatorDC-DC ConverterLow Power ModesELCInterrupt ControllerVBAT	<h4>Safety</h4> <ul style="list-style-type: none">Memory Protection UnitSRAM Parity CheckECC in SRAMPOEClock Frequency Accuracy MeasurementCRC CalculatorIWDTData Operation CircuitMRAM Area ProtectionADC Self TestPermanent Lock FunctionProgrammable Voltage Detector	<h4>Security</h4> <ul style="list-style-type: none">AES (128/192/256), CHACHA20RSA 4K, ECCTRNGSHA-2 (224/256/384/512), SHA-3Secure DebugFirst Stage Boot LoaderOTP (Immutable storage)TrustZone EFP supportCMAC/HMAC/GMACDPA/SPA Side Ch. Protection
			<h4>Package</h4> <p>BGA 224/ 289/ 303</p>

EFFICIENT SYSTEM PARTITIONING WITH DUAL CORES

Combining high performance tasks with real-time control, sensors and communication

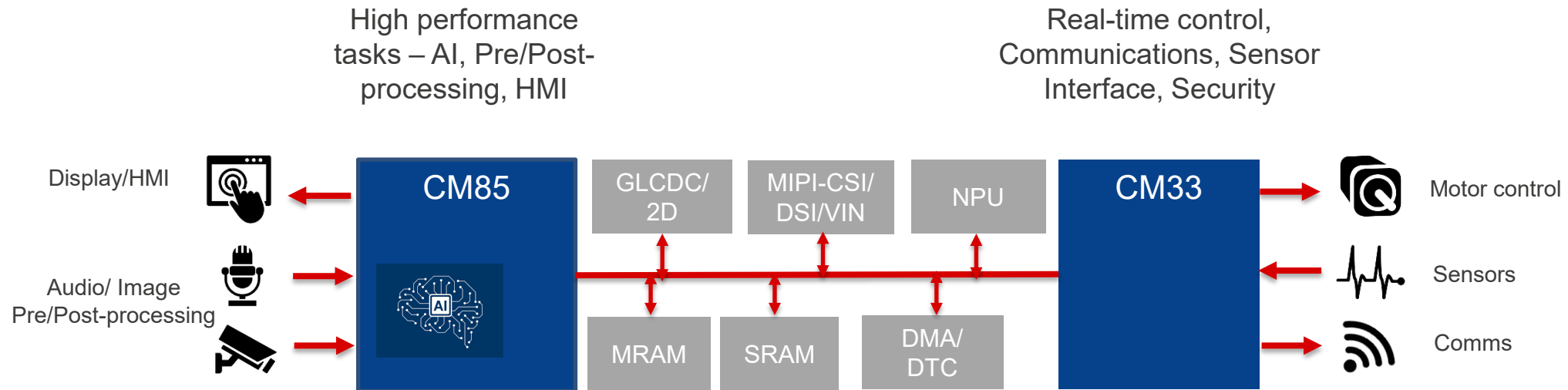

- Dual cores enable efficient partitioning of system tasks
- Either core can be configured as the master or slave CPU and can be independently powered
- CM33 core allows low-power wake-up and operation, while higher performance CM85 core stays in low power mode until required for high compute tasks

AI-DEDICATED ACCELERATION: EQUIPPED WITH ETHOS-U55

- By utilizing the Ethos-U55 NPU, AI inference performance can be up to 35 times faster compared to processing with a CPU alone.
- Ideal for edge/endpoint AI applications such as image classification and object detection.

What is Ethos-U55 NPU? : An AI-dedicated accelerator from Arm, boasting a maximum AI computing capability of 256 GOPS at 500MHz.

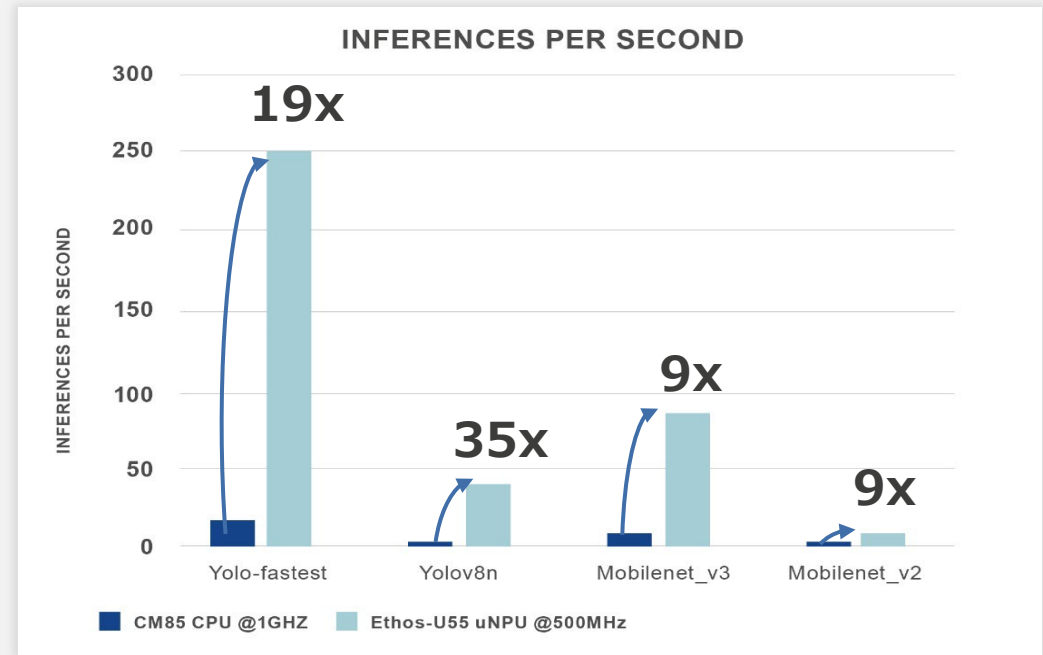
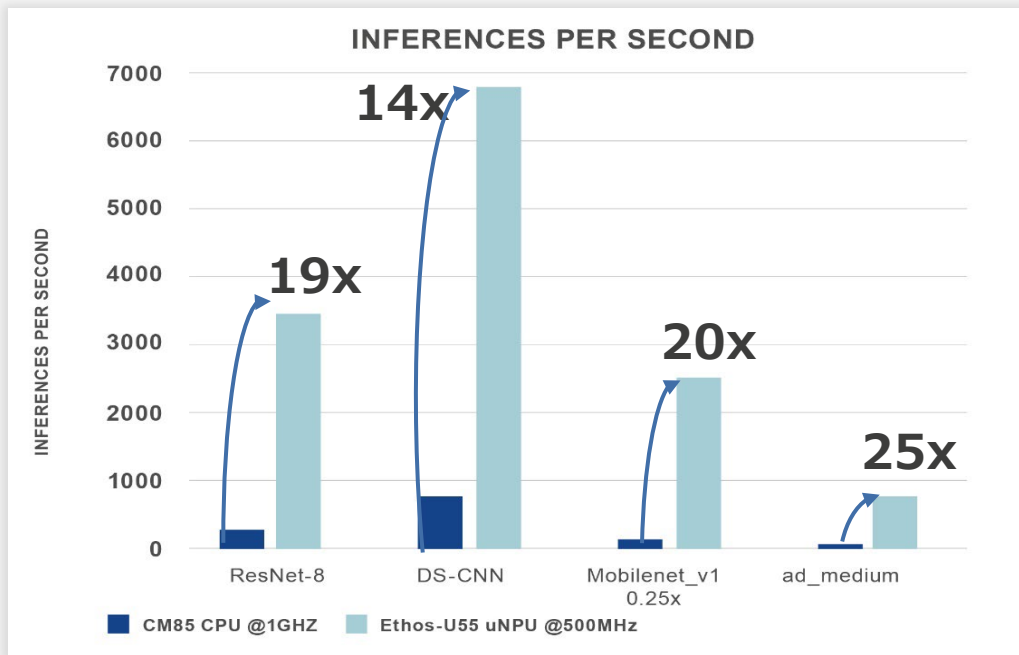

Used AI model

- Image Classification - ResNet8, MobileNetV2, MobileNetV3
- Keyword Spotting - DS-CNN
- Visual wake words - MobileNet v1
- Object detection - Yolo_fastest, YOLOv8N
- Anomaly detection - ad_medium

MULTIPLE MEMORY TOPOLOGIES POSSIBLE

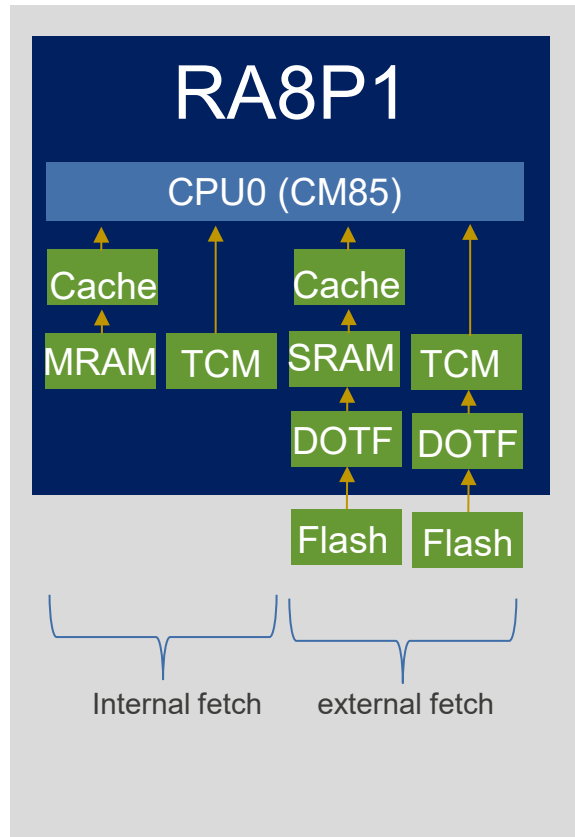

Single Core

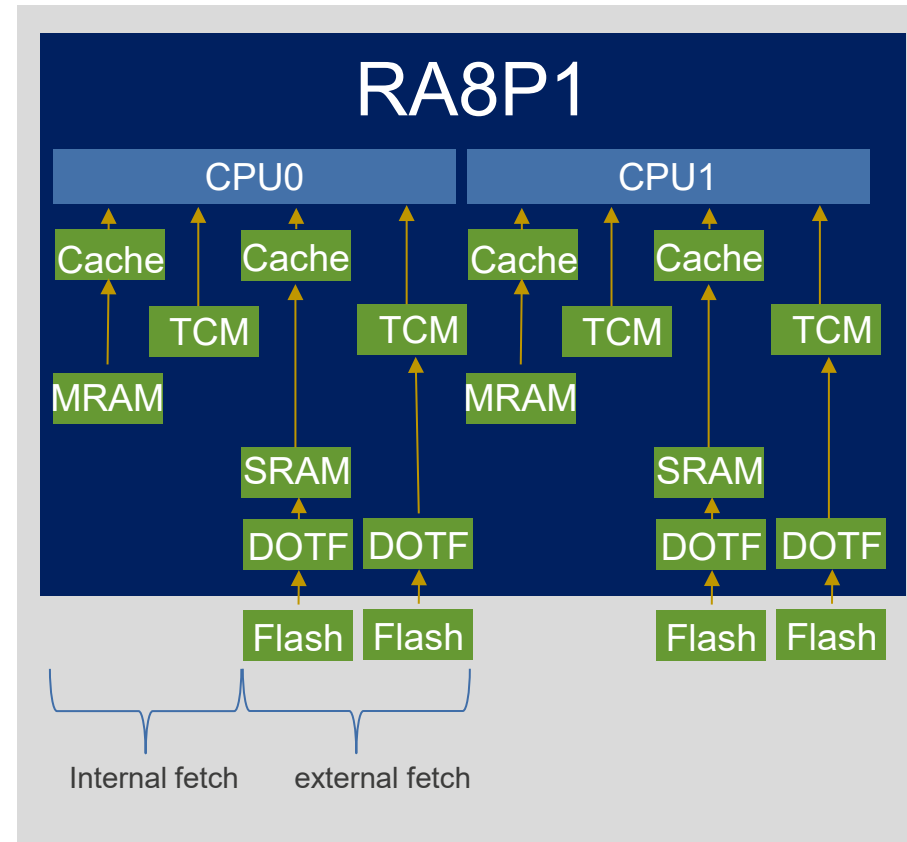

Dual-Core

- Use internal memory for lowest latency and power consumption and highest security
- Use DOTF for higher security with ext. flash - if security is not required, DOTF can be bypassed
- Use Cache or TCM (with 0 wait states) for highest performance
- On dual-core MCUs, all on-chip memory can be shared by the two cores except for TCM and caches
- Internal fetch is MRAM + cache or TCM
 - On dual-core, MRAM conflict could occur
 - On dual-core, when both cache miss occurs, there is a possibility of a reload wait from MRAM due to access conflict
- External fetch is
 - Ext-flash + cache via DOTF **OR**
 - Ext-flash + SRAM + cache via DOTF

ADVANCED INTERFACES FOR VOICE AND VISION AI

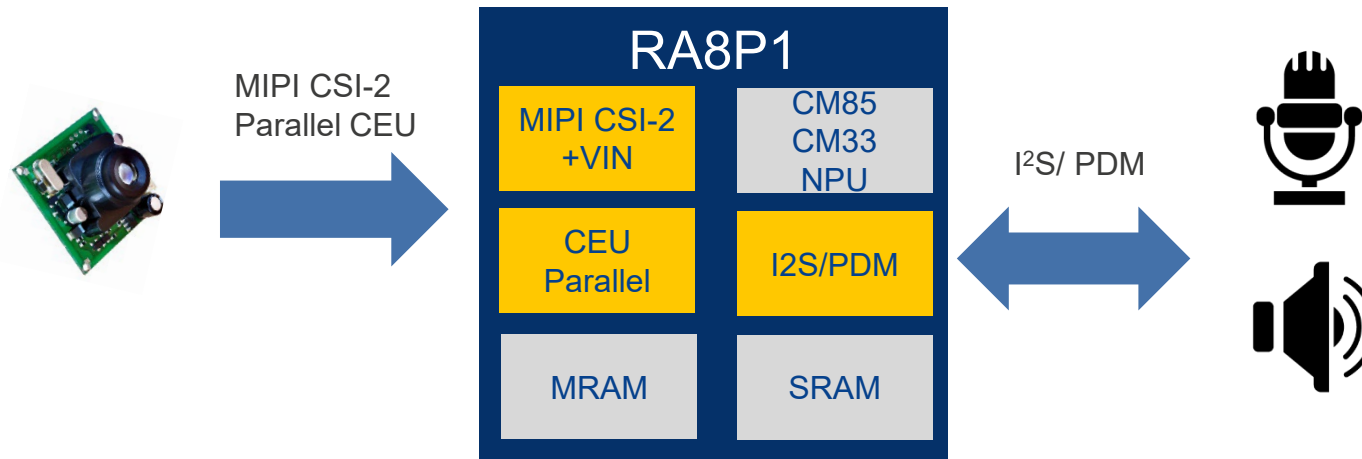

MIPI CSI-2 camera interface

- Up to 2 lanes, 80 Mbps to 720 Mbps/lane
- Image signal received by MIPI CSI-2 is output to the VIN module

VIN Image scaling module

- Captures YUV and RGB data inputs via MIPI CSI-2 interface
- Vertical and horizontal scaling up to 3x
- Color space conversion from YUV to RGB, RGB to YUV, RGB to ARGB

16/8-bit CEU camera interface

- Captures image data and moves it to memory

PDM Interface

- Up to 3 channels; outputs pulse density modulated signals
- Filters & converts 1-bit digital input data (pulse density modulated at a high sampling rate) into 20-bit or 16-bit digital data (at a lower sampling rate) for sound detection

I2S Interface

- Serial interface for transmitting I2S/Monaural/TDM audio data
- Operates as a slave or master, receiver, transmitter, or transceiver to suit various applications

HMI FEATURES ENABLE HIGH RESOLUTION GRAPHICS

MCU Features

- Graphics LCD Controller with parallel RGB & MIPI DSI interfaces
- 2D Drawing Engine
- MIPI CSI-2/ VIN & 8/16bit parallel camera interfaces
- Large 2MB SRAM – No external memory needed for low-to-mid resolution displays
- 32bit SDRAM interface

RA8P1-EK AI Kit enables rapid prototyping

- Camera module supports both MIPI-CSI and parallel interfaces
- Connectors to attach Parallel or MIPI DSI LCD panels

Flexible Software Package with Graphics support

- Native support for SEGGER emWin and Microsoft GUIX graphics libraries
- Graphics peripheral drivers

Rich Ecosystem Partner network



Microsoft



Embedded Wizard

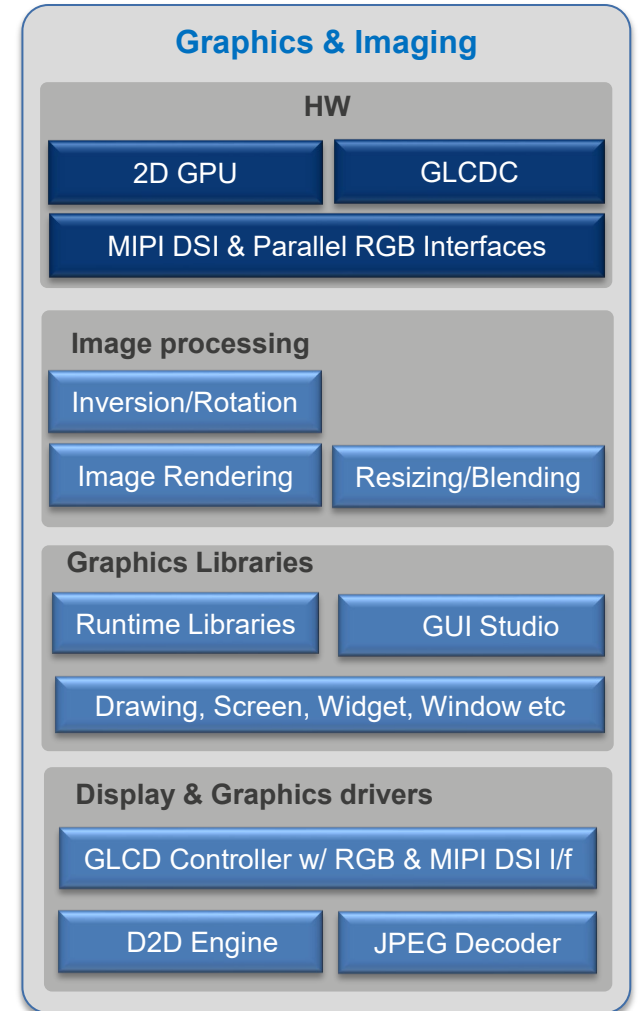

DEVELOPMENT FRAMEWORK TO ACCELERATE AI APPLICATION DEVELOPMENT

COMPREHENSIVE SUPPORT FROM MODEL CONVERSION TO CODE GENERATION

- Renesas' AI model conversion tool "RUHMI" supports TensorFlow Lite and ONNX formats, and provides integrated support for conversion, quantization, and code generation.
- The "EK-RA8P1" is an evaluation board ideal for AI and image processing application development

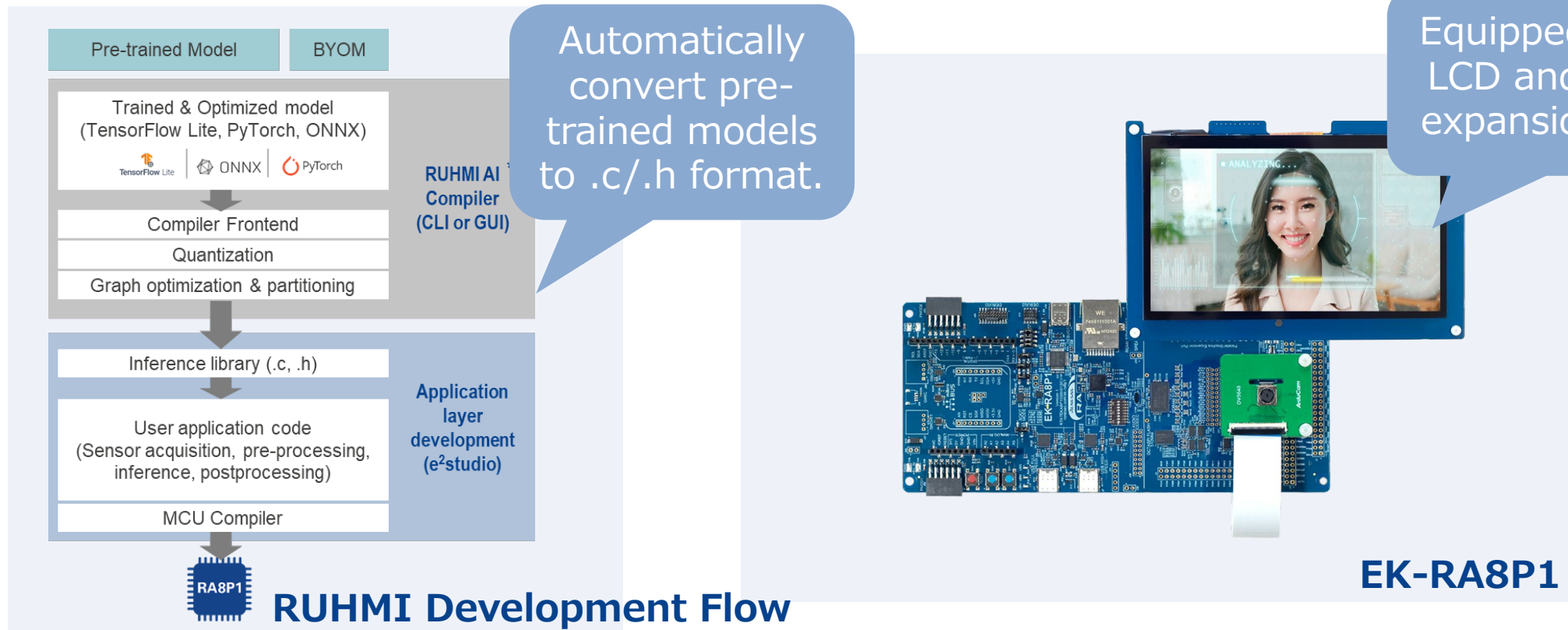

SUPPORTING APP DEVELOPMENT ENVIRONMENTS AND TOOLS

FLEXIBLE SOFTWARE PACKAGE (FSP)

HIGHLIGHTS OF IOT RA PRODUCT LINE

Accelerate Secured IoT Developments with FSP

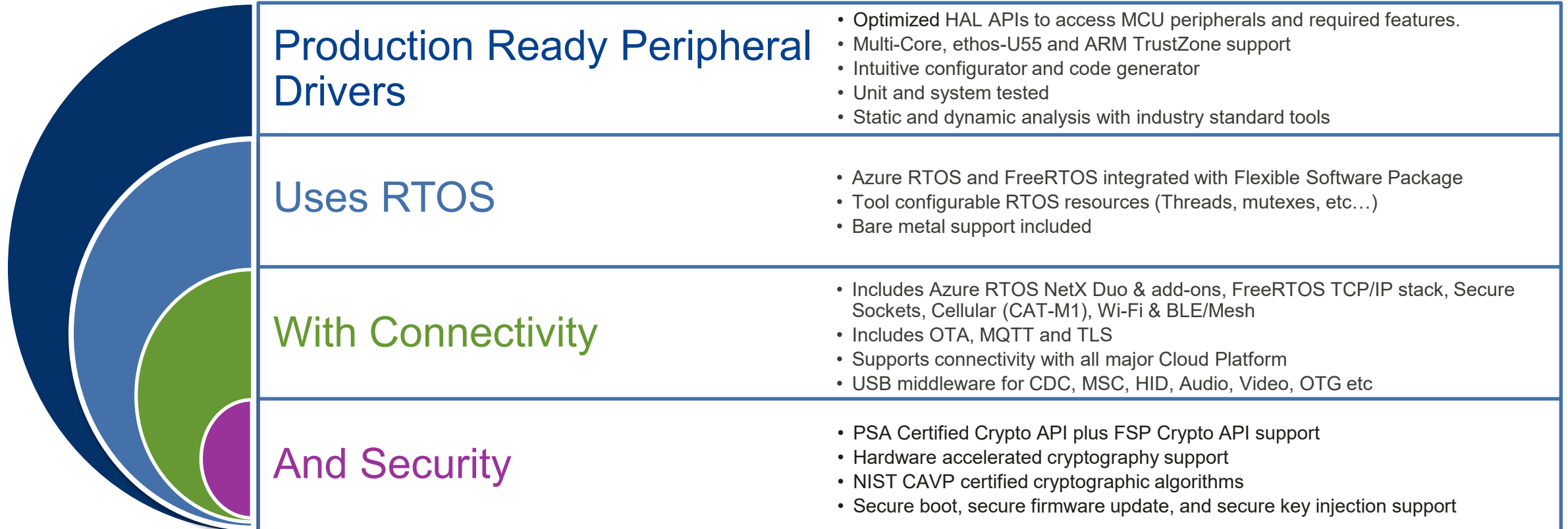

FSP has the track record of 5+ years in the Global Industrial and Consumer Market



FLEXIBLE SOFTWARE PACKAGE (FSP)

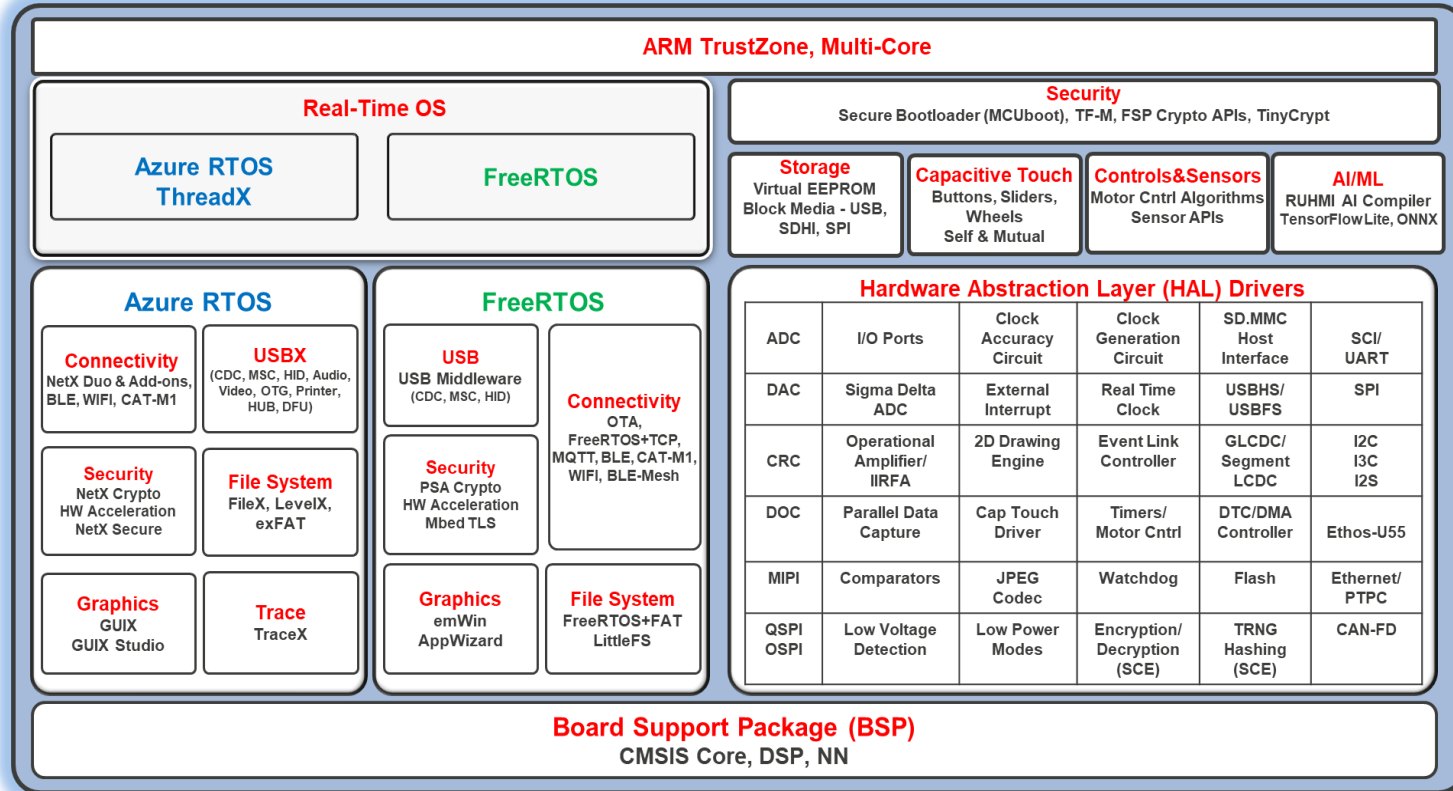

Benefits

- Easy-to-use, scalable, high-quality software for embedded designs using Single and Dual-Core RA Family Microcontrollers
- Best-in-class HAL drivers with high performance and low memory footprint.
- Middleware stacks with Azure RTOS and FreeRTOS integration to ease the implementation of complex modules like communication and security
- The e² studio IDE with intuitive configurators and intelligent code generation to make programming and debugging easier and faster
- Open software ecosystem and flexibility in using bare-metal programming, included Azure RTOS and FreeRTOS, your preferred RTOS, legacy code, and third-party ecosystem solutions
- Integrated package with all required components for easy setup and start of development
- Support for Windows, Mac OS and Linux
- Complete source code available through GitHub



RA FAMILY DEVELOPMENT ENVIRONMENT

FLEXIBLE AND EASY TO USE

On-Chip Debug

- Renesas E2 & E2 Lite

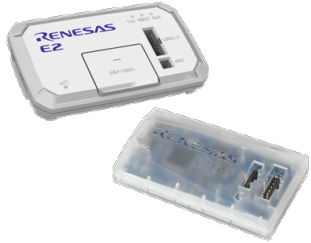

- SEGGER J-Link



- Flash programmer
 - PG-FP6
 - RFP
 - A wide choice of 3rd party solution



IDE

- Renesas e² studio



- Visual Studio Code



- Keil MDK



- IAR Embedded Workbench



Compiler

- GNU



- LLVM



- Arm Compiler V6



- IAR ARM Compiler



Support Tools

- FSP driver selection and configuration

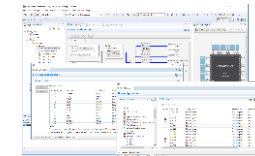

- Intelligent pin mapping

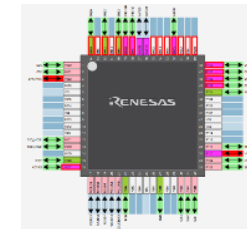

- QE Tools



Kits and Boards

- Evaluation Kits

- | | |
|-------------------|-------------|
| ▪ EK-RA2A1 | ▪ EK-RA4E2 |
| ▪ EK-RA2L1 | ▪ EK-RA6M1 |
| ▪ EK-RA2E1 | ▪ EK-RA6M2 |
| ▪ EK-RA2E2 | ▪ EK-RA6M3 |
| ▪ EK-RA4W1 | ▪ EK-RA6M3G |
| ▪ EK-RA4M1 | ▪ EK-RA6M4 |
| ▪ EK-RA4M2 | ▪ EK-RA6M5 |
| ▪ EK-RA4M3 | ▪ EK-RA6E2 |
| ▪ EK-RA8M1 | ▪ EK-RA8D1 |
| ▪ EK-RA4L1 | ▪ EK-RA8E2 |
| ▪ EK-RA8P1 | |

- Fast Prototyping Boards

- | | |
|--------------------|-------------|
| ▪ FPB-RA2E1 | ▪ FPB-RA6E1 |
| ▪ FPB-RA2E2 | ▪ FPB-RA4E2 |
| ▪ FPB-RA4E1 | ▪ FPB-RA6E2 |
| ▪ FPB-RA8E1 | |

- Solution Kits

- | | |
|--------------|--------------|
| ▪ RSSK-RA6M2 | ▪ RSSK-RA2L1 |
| ▪ RSSK-RA6T1 | ▪ MCK-RA6T2 |
| ▪ MCK-RA4T1 | ▪ MCK-RA6T3 |
| ▪ MCK-RA8T1 | ▪ MCK-RA6M5 |

EASY TO USE: RA8P1 VISION AI DEVELOPMENT SUPPORT TOOL

- e² studio: Integrated development environment for Renesas products. Allows for seamless execution from sample code download to debugging
- AI navigator: e² studio plugin that provides a GUI-based guide for implementing pre-trained AI models into projects
- RUHMI Framework: Optimizes pre-trained models and converts file formats for RA8P1

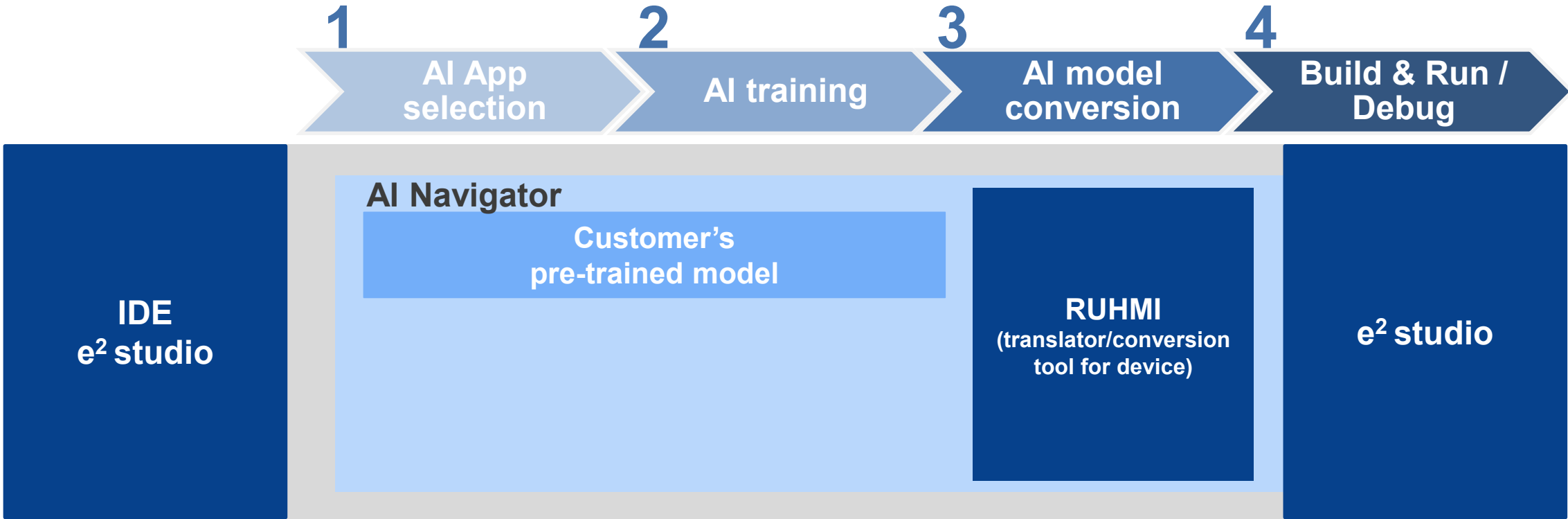

DEVELOPMENT FLOW USING AI NAVIGATOR WITH RA8P1

- AI Navigator guides you through the AI software development flow, making it easy to develop AI applications

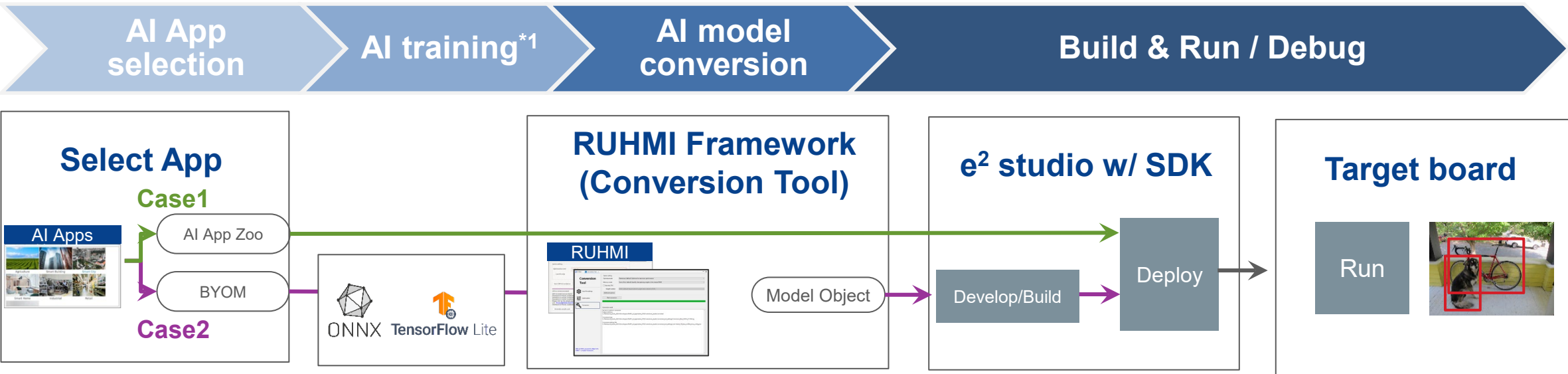

- Select an AI app based on your use case
- Learned using AI Framework
- Convert AI models with RUHMI
Generate C language source code optimized for Ethos-U55 and CM85
- Develop and build the AI application on e2 studio, then deploy it to the evaluation board. Afterward, run the AI application on the evaluation board.

AI training*1 : Transfer Learning
 A machine learning technique that uses a model trained for a specific task as a starting point for a model that performs a similar task. Faster and easier than learning from scratch

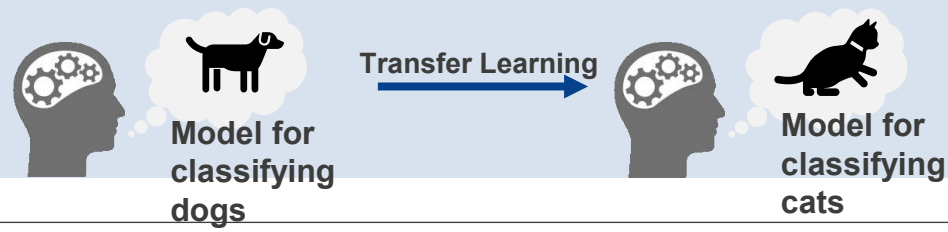

AI WORKFLOW USING ETHOS-U55

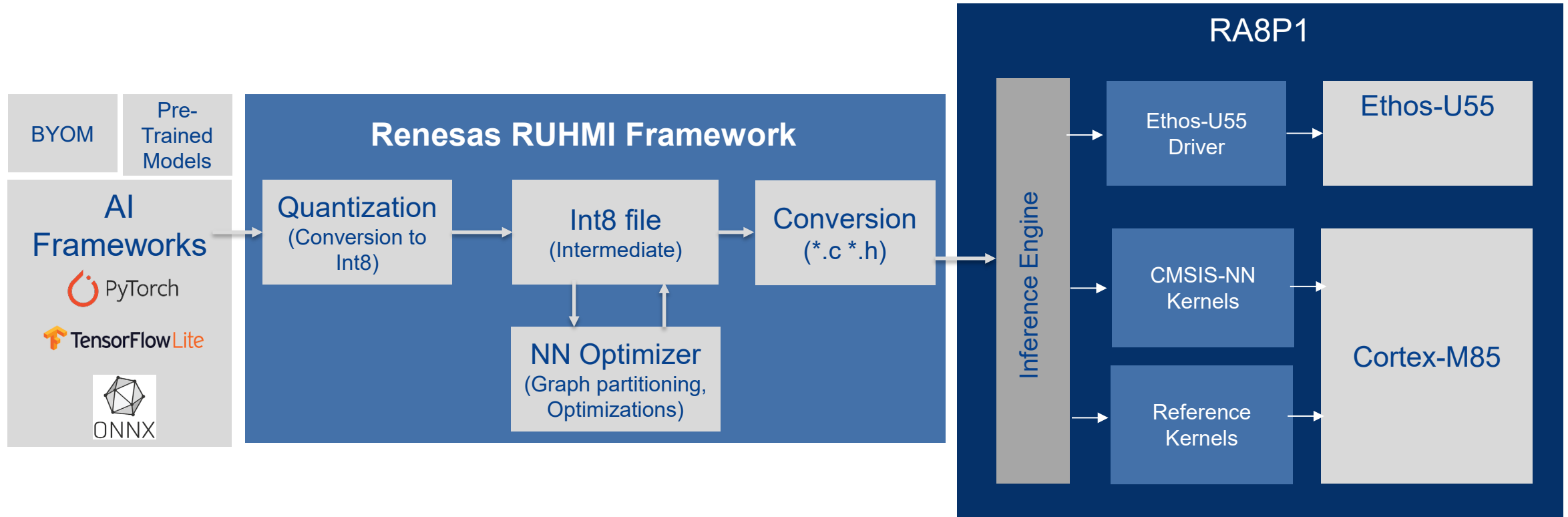

EK-RA8P1 - EVALUATION KIT FOR RA8P1

Key Features

Special Feature Access

- 2-Lane MIPI DSI & Parallel Graphics Display Connectors
- Camera Expansion Connector, supports both CEU and MIPI CSI-2
- USB High Speed Host & Device
- 64 MB External OSPI Flash
- 64 MB SDRAM
- PDM MEMS Microphones & Audio codec with speaker out connections
- Ethernet (RJ45 RGMII interface)

MCU Native Pin Access

- R7KA8P1KFLCAC MCU
- 1GHz, Arm Cortex®-M85 core and 250MHz, Arm Cortex®-M33
- 1 MB MRAM, 2MB SRAM w/ECC
- 289 pins, BGA package
- Native pin access
- MPU & USB current measurement

Ecosystem & System Control Access

- USB Full Speed Host & Device
- 5 V input through USB (Debug, HS, FS) or external power supply
- Debug on-board (SWD & JTAG)
- Debug in (SWD, SWO, ETM, JTAG)
- Debug out (SWD, SWO, JTAG)
- 3 User LEDs & 2 User buttons
- 2 SeedGrove® system (I2C & analog)
- 2 Digilent Pmod™ (I2C, SPI or UART selectable)
- Arduino™ (Uno R3)
- MikroElektronika™ mikroBUS
- SparkFun® Qwiic® (I2C)
- MPU boot configuration switch

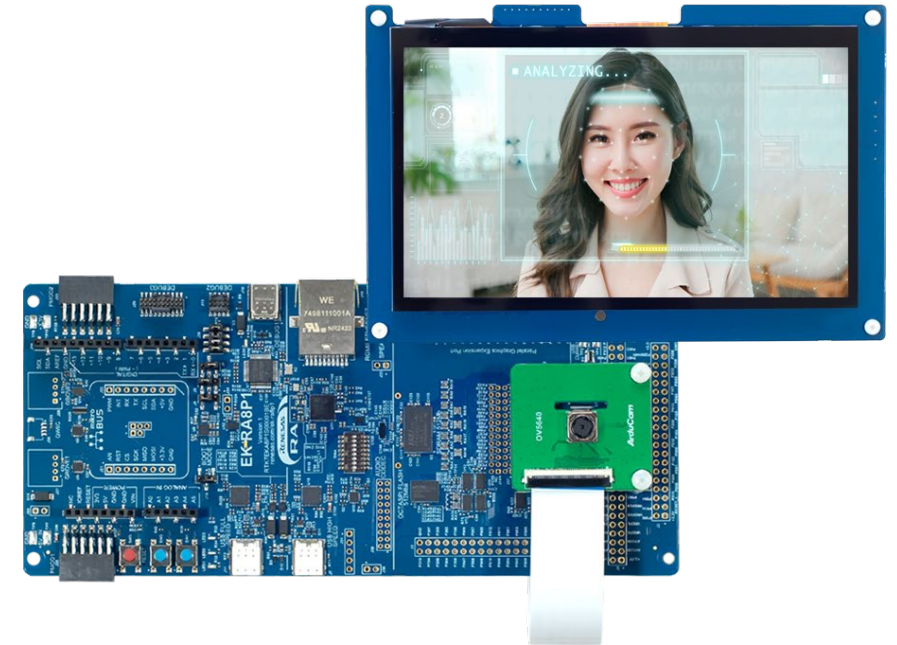

www.renesas.com/ek-ra8p1

(User manual, quick start guide, development tools, schematics, design files & example projects)

RTK7EKA8P1S01001BE

(Orderable part number)



プロジェクト・エクスプローラー

- vision_ai_ethosu_mipicsi_glcd_ek_ra8p1_llvm_mera_yolo_fastest [Debug]
 - バイナリー
 - Includes
 - ra
 - ra_gen
 - src
 - Debug
 - assets
 - conversion_results
 - conversion_tool_settings
 - Conversion_Tool_250911_181240.log
 - Conversion_Tool_250916_165809.log
 - Conversion_Tool_250917_000306.log
 - Conversion_Tool_250917_093037.log
 - Conversion_Tool_250917_093044.log
 - Conversion_Tool_250917_093114.log
 - Conversion_Tool_250917_093127.log
 - Conversion_Tool_250917_093641.log
 - Conversion_Tool_250917_093651.log
 - Conversion_Tool_250917_093704.log
 - Conversion_Tool_250917_093718.log
 - Conversion_Tool_250917_093729.log
 - Conversion_Tool_250917_093739.log
 - yolo-fastest_192_face_v4.tflite_input_shape.json
 - yolo-fastest_192_face_v4.tflite_model_info.json
 - yolo-fastest_192_face_v4.tflite_trans_config.json
 - converted
 - ra_cfg
 - script
 - configuration.xml
 - lLinkLog.log
 - ra_cfg.txt
 - README.md
 - vision_ai_ethosu_mipicsi_glcd_ek_ra8p1_llvm_mera_yolo_fastest.llink
 - vision_ai_ethosu_mipicsi_glcd_ek_ra8p1_llvm_mera_yolo_fastest.launch
 - yolo-fastest_192_face_v4.tflite
 - Developer Assistance

AI Navigator

AI アプリ選択

ボード上で実行

もっと知るには

Create New AI with...

Select Sample AI Application

- Select AI Application
- Transfer Learning
- Convert
- Build
- Run

Use Your Project & AI Model

- Select Project
- Select AI Model
- Convert
- Build
- Run

プロジェクト:

vision_ai_ethosu_mipicsi_glcd_ek_ra8p1_llvm_mera_yolo_fastest

継続

RENESAS

更新が利用できません

ソフトウェアで更新が利用できます。更新をレビューしてインストールします。
[リマインダーオプションを設定](#)

アウトライン

アウトラインを提供するアクティブなエディターはありません。

問題 コンソール × プロパティ スマート・ブラウザ スマート・マニュアル

RA FSP

SUMMARY



SUMMARY & KEY TAKEAWAYS

- Equipped with the **Ethos-U55 NPU**, which boasts **up to 256 GOPS** of AI computing power, it enables advanced AI
- Dual-core configuration featuring the Arm Cortex-M85 and Cortex-M33
- Equipped with peripheral functions that support a wide range of HMIs, including image and audio input/output and LCD display
- Accelerating Development with “RUHMI,” Renesas' Proprietary AI Development Framework
- Supporting smooth product development with a comprehensive suite of software and development
- **Vision AI Sample Projects and Evaluation Kits for the RA8P1: Get started today with the EK-RA8P1 and experience developing edge AI applications on an MCU**

[Deploy Smarter with the Renesas RUHMI Framework: Quantize, Optimize, and Run AI Models | Renesas ルネサス](#)

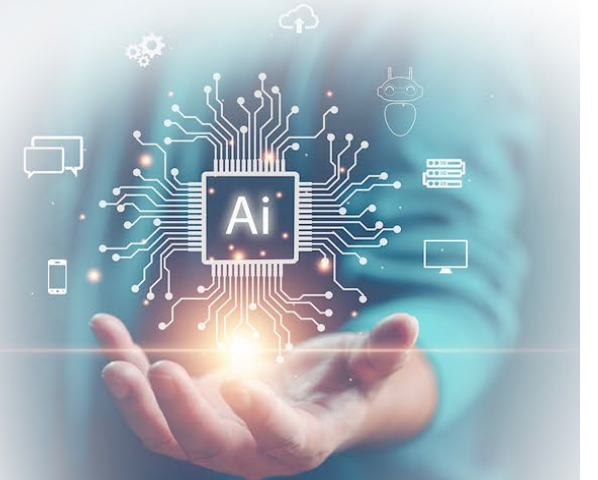

[Renesas.com](https://www.renesas.com)