

# **T-Engine Reference Board**

U00B0021-02

## **Hardware Manual**

**Rev 1.01**

June 7, 2011

## Important Matters

This document is created with great care at the time of its issue, and our company assumes no responsibility for any consequence caused by using this document in case any errors are contained or there are undocumented matters herein. Our company may change the specification of the products described in this document for the improvement or change in their functions without any special notification or modification to this document. This document does not permit the use of intellectual property rights including our company's or a third party's patent related to semiconductors, parts, circuits described herein. Our company assumes neither the responsibility nor obligation of guaranteeing adaptability and reliability to meet each customer's specific purpose regarding the products described herein. Furthermore, our company is not held responsible if any trouble or failure is caused to customers' devices or systems by connecting or embedding the products described herein.

The parameter described as "Typical" may have a different value depending on the customer's application. The products described herein are manufactured to be used for general electronic devices and are products for standard use. They are not intended for use for aerospace instrument, trunk line communication equipment, nuclear power control equipment, medical equipment that concerns life support, etc, which require extremely high reliability and safety. The trader that sells the products herein must make sure to present this Important Matters to their customers and make efforts to have them understand the matters.

When exporting any product that falls into "a strategic material" under Foreign Exchange and Foreign Trade Act among the ones described herein, an import permit/approval based on the said law is required.

T-Engine Reference Board

U00B0021-02 Hardware Manual Rev 1.01

Copyright 2011 Ubiquitous Computing Technology Corporation

All rights reserved. No part of this publication may be reproduced, stored in a retrieval system, or transmitted in any form or by any means, electric or mechanical, by photocopying, recording, or otherwise, without the prior written consent of Ubiquitous Computing Technology Corporation.

Ubiquitous Computing Technology Corporation

2-20-1 Nishi-gotanda, Shinagawa, Tokyo, 141-0031 JAPAN

Home Page : <http://www.uctec.com>

E-mail: [sales@uctec.com](mailto:sales@uctec.com)

## Notes on Use and Handling

Please follow the following instructions below to use this product safely. If these instructions are not followed, an electric shock, an injury, a fire, machine failure, etc. may result.



### Lightening is dangerous

Do not install this product, cables, etc., when there is lightening. You may get an electric shock from lightening.



### Handle with care

Do not drop, hit with something or give strong shock to the product.



### Do not disassemble

Do not remove the screws, and do not disassemble the case.



### Be cautious of static electricity

This product uses parts susceptible to static electricity. As these parts may be destroyed by static electricity, do not touch the point of contact of the connector or the parts bare-handed.



## Attention at time of installation and removal

Make sure to switch off this product before installing connectors and cables to it. If the installation is performed while the power is on, it may cause failure of this product or connected products.



## Pull out power plug from AC outlet

Pull out the power plug from the AC outlet immediately when smoke comes out, or there is a strange smell or sound. If you keep on using the product, a fire may be caused by short circuit and you may get an electric shock. Furthermore, other devices may be impacted.



## Do not use or store the product in following places

- Place subjected to direct sunlight
- Place with rapid temperature change (where dew condensation occurs)
- Humid place, or place where liquid such as water may reach the product
- Place where vibration is intense
- Dusty place and place where carpet is laid (it may cause electrostatic failure)
- Place where corrosive gas is generated
- Do not put the product directly on conductive thing (it may cause failure)

## Table of Contents

Revision History.....	5
1 Product Summary.....	5
2 Block Chart.....	6
3 Function.....	7
3-1 Power Supply.....	7
3-2 Power Control.....	8
3-3 Reset.....	9
3-4 RTC.....	9
3-5 LAN.....	10
3-6 LCD.....	11
3-6 USB.....	12
3-7 Micro SD Memory Card Interface.....	13
3-8 eMMC NAND Flash Memory.....	13
3-9 NOR Flash Memory.....	14
3-10 USB-UART.....	14
3-11 UART.....	15
3-12 SOUND.....	16
3-13 High Speed Link System (HLS).....	17
3-14 LED.....	17
3-15 Isolated Input/Output.....	18
3-16 Camera Interface.....	18
3-17 Illuminance Sensor.....	19
3-18 Temperature Sensor.....	19
3-19 JTAG.....	20
3-20 Switch.....	21
4 GPIO Connection and Setting.....	21
5 AB0 Address Allocation.....	22
6 Memory Map.....	23
7 External View of Board.....	24
7-1 Parts Side.....	24
7-2 Connector Position on Solder Side.....	24
8 Circuit Diagram.....	25

## Revision History

Rev.1.0	2011.05.17	First edition
Rev.1.01	2011.05.27	Corrected the description of power feeding from USB

## 1 Product Summary

This product is a small computer board that can be used as a reference board that operates T-Kernel 2.0. It can be used for device control, factory automation, instrumentation, etc, as an execution board equipped with various interfaces and real-time OS. Also, by connecting LCD with a touch panel, a device that can be operated using graphical user interface can be built.

### Main Specification

- CPU: EMMA Mobile1-D (ARM11 Core Input clock = 32.768KHz Maximum operating frequency 500MHz) – In the following explanation, the product may be referred to as EM1D.
  - Built-in DDR-SDRAM (64MB)
  - Boot mode: following 3 kinds
  - Micro SD boot
  - eMMC boot
  - AB0 (NOR FLASH) boot
- Power supply IC: DA9052 (manufactured by Dialog)
- RTC: RX-4581NB (manufactured by Epson Toyocom)
  - Backup by lithium primary battery (backup duration: 10 years)
- LAN: LAN9221 (manufactured by SMSC) 10/100BASE-T (1 channel) RJ-45, WAKE on LAN function
- LCD: WVGA (800\*480), RGB666, touch panel (resistive film type)
- USB: USB2.0 (MINI-AB) 1ch
- Micro SD: EM1D built-in SD/memory card interface
- eMMC NAND flash memory: 4-bit connection, 4GB
- NOR flash memory: 16-bit connection, 32MB
- USB to UART conversion: CP2103 (manufactured by Silicon Laboratories), equipped with 4-bit GPIO
- Sound: ML7037 (manufactured by OKI SEMICONDUCTOR, with built-in echo canceller), microphone input, speaker output
- HLS: MKY36 (manufactured by Step Technica), remote I/O host function
- LED: 4 bit
- PUSH SW: 4 bit (directly connected to EM1D)
- Isolated input/output: Isolation by photo coupler, 4-bit input, 4-bit output
- Camera that can be used (optional): NCM03-V (manufactured by Asahi Electronics Laboratory), VGA resolution
- Illuminance sensor: Ambient Light Sensor BH1710 (manufactured by ROHM)
- Temperature sensor: AD7814 (Analog Devices)
- JTAG: compatible with PARTNER-Jet manufactured by Kyoto Microcomputer
- Serial : RS-232 (2 channels), 3-pin connector x 2
  - CMOS level (2 channels), 6-pin connector
  - \*The above-mentioned RS-232 and CMOS level are switched by the dip switch for each channel.
- Power supply: DC+5V
- Size: 137mm x 75mm \*Excluding connector and protruding parts
- Operating temperature: TBD
- Current consumption: TBD Typ (5V)

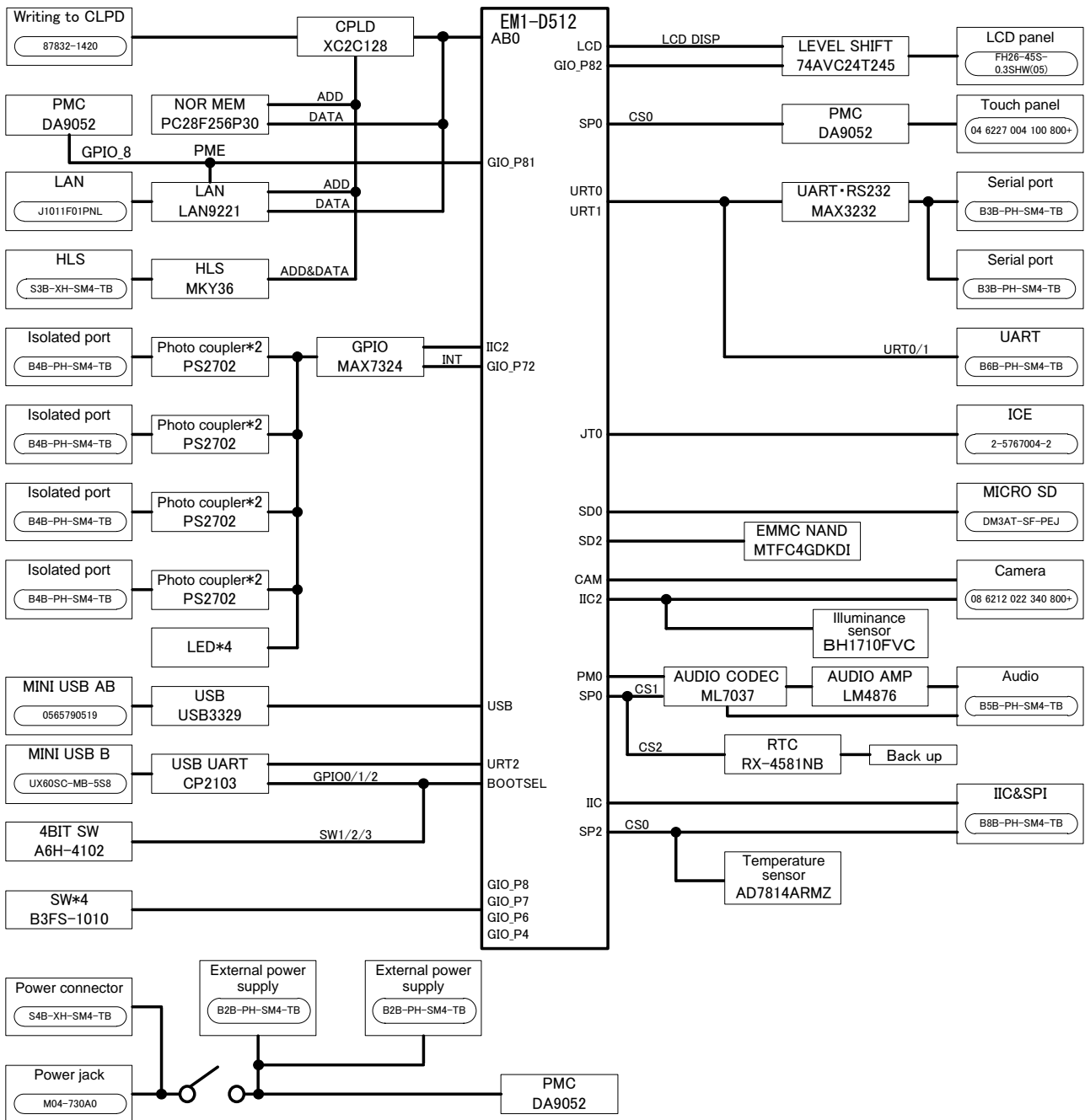

### 3 Function

#### 3-1 Power Supply

This reference board has two kinds of power connectors: A DC jack and a power supply connector (XH connector). The power supply connector (XH connector) is used when it causes trouble if the connector comes off easily, for example when embedding it into a device. As the two connectors are connected internally, do not supply power to these two connectors at the same time. Power is supplied when either of the connectors is connected to the power and the switch is turned on.

Power supply voltage: DC5V±5%

Power supply current: Max 2A

#### Connector DC Plug

Compatible plug: φ 1.7-mm DC plug (Externally φ 4mm), EIAJ RC5320A type2

Jack used on the board side: M04-730A0 (Marushin Electric)

Connector No.: J2

Polarity: Center +

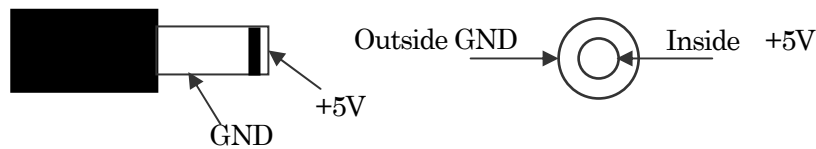

#### Power supply connector (XH connector)

Connector used on the board side: S4B-XH-SM4-TB

Connector No.: J1

Pin number	Allocation	Remarks
1	DCIN	Ext. 5V supplied externally
2	DCIN	Ext. 5V supplied externally
3	GND	Ground
4	GND	Ground

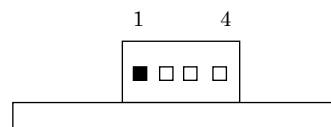



### 3-2 Power Control

The power of this board is controlled by the power supply IC “DA9052” (manufactured by Dialog). It is connected to Serial Peripheral Interface built into EM1D and SP0 (Chip Select=CS0). By making settings to this device, a transmission to various low power consumption modes is possible.

<Connection diagram>

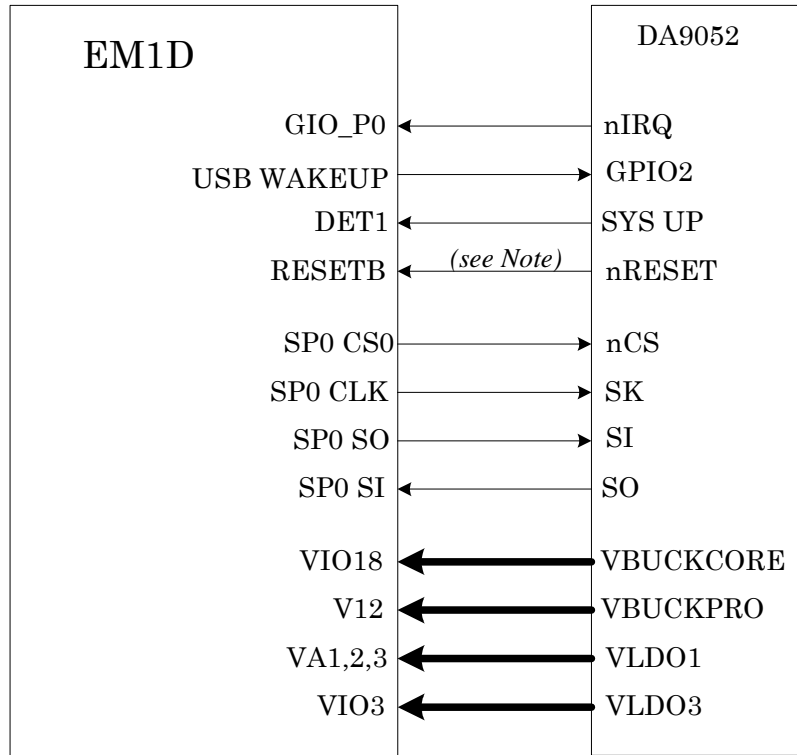

(Note) Refer to 3-3 “Reset” for the connection of RESETB.

### 3-3 Reset

This reference board is reset by nRESET signal of power on reset of DA9052, reset signal of ICE and the reset switch.

<Connection diagram>

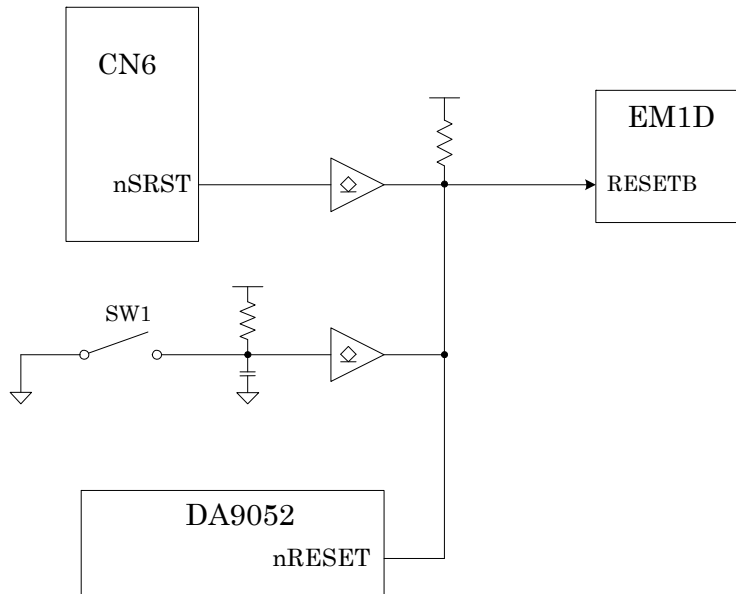

### 3-4 RTC

RX-4581NB manufactured by EPSON TOYOCOM is used. This device is connected to SP0 (SP0\_CS2) of EM1D. It is backed up by lithium primary battery.

<Connection diagram>

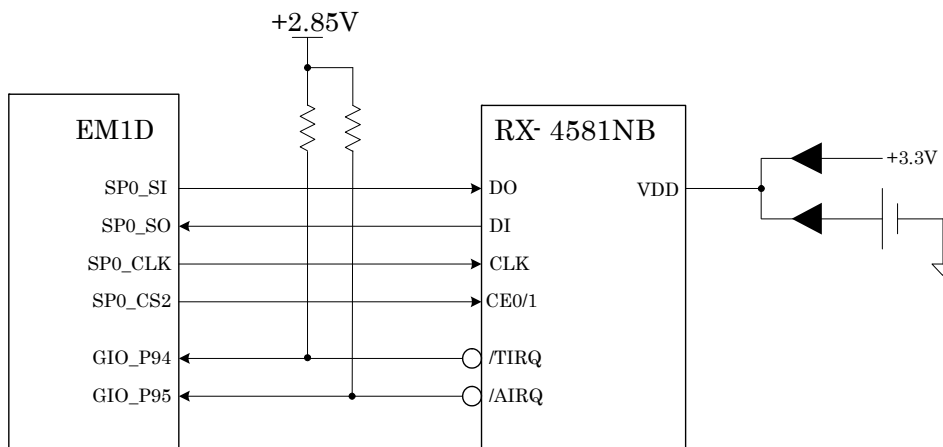

### 3-5 LAN

LAN is connected to External Bus Interface (AB0) of EM1D. As the chip select signal, AB0\_CS3 is used.

Resetting of this device is controlled by “GIO-P44” port of EM1D. The reset state is generated when it is “0.” Also, interrupt signal is connected to “GIO-P41,” and an interrupt is generated when it is “1.”

This device supports the Wake on LAN function. To use the function, it is necessary to perform the setting to permit Wake on LAN on the LAN controller, and set the power control IC to the wait state. When a magic packet is received from LAN at this state, the start process will be initiated.

<Connection diagram>

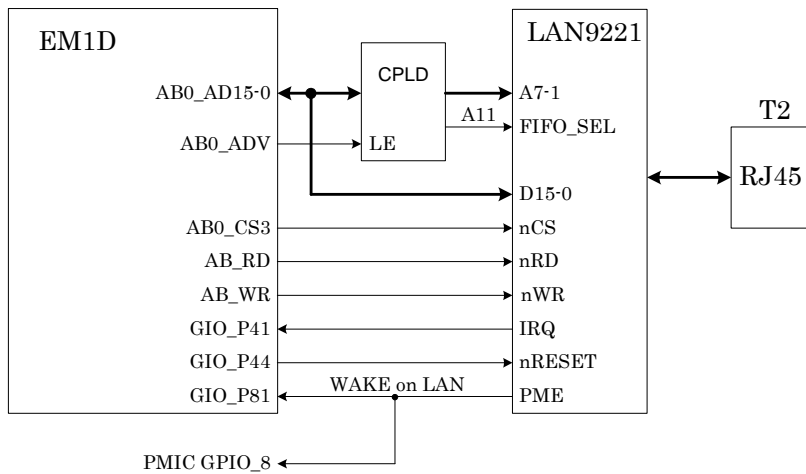

Used connector: J1011F01PNL (manufactured by Pulse)

Connector No.: T2

Pin No.	Signal name	Remarks
1	TPO+	Transmission (positive)
2	TPO-	Transmission (negated)
3	TPI+	Receive (positive)
4	NC	
5	NC	
6	TPI-	Receive (negated)
7	GND	
8	GND	

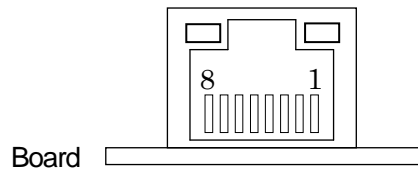

(Note) NC is not used (open).

### 3-6 LCD

The LCD controller built into EM1D is used. The display is in RGB666 due to the specification of the LCD controller.

<Connection diagram>

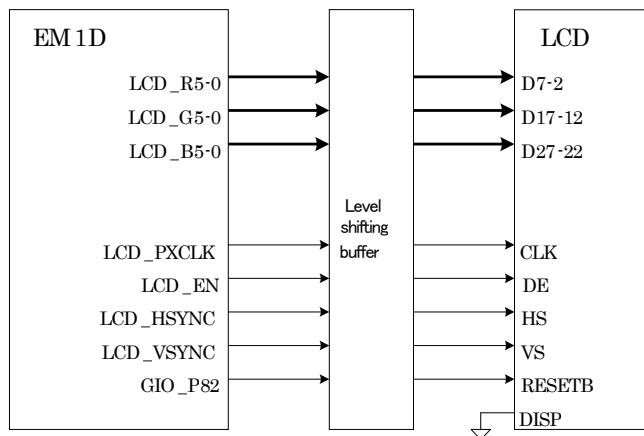

Used connector: FH26-45S-0.3SHW(05) (manufactured by HIROSE ELECTRIC)

Connector No.: CN15

Terminal No.	Signal name	Remarks	Terminal No.	Signal name	Remarks
1	GND		24	D22	Blue 2 bits
2	TP4	NC	25	D21	Blue 1 bit (PD)
3	TP3	NC	26	D20	Blue 0 bit (PD)
4	TP2	NC	27	D17	Green 7 bits
5	TP1	NC	28	D16	Green 6 bits
6	LED2-	Back light	29	D15	Green 5 bits
7	LED2+	Back light	30	D14	Green 4 bits
8	LED1-	Back light	31	D13	Green 3 bits
9	LED1+	Back light	32	D12	Green 2 bits
10	DISP	Display on and off	33	D11	Green 1 bit (PD)
11	VS	Vertical synchronizing signal	34	D10	Green 0 bit (PD)
12	VDC	Power supply voltage	35	D7	Red 7 bits
13	VDC	Power supply voltage	36	D6	Red 6 bits
14	CLK	Pixel synchronizing signal	37	D5	Red 5 bits
15	GND		38	D4	Red 4 bits
16	HS	Horizontal synchronizing signal	39	D3	Red 3 bits

17	DE	Data valid	40	D2	Red 2 bits
18	RESETB	Reset input	41	D1	Red 1 bit (PD)
19	D27	Blue 7 bits	42	D0	Red 0 bit (PD)
20	D26	Blue 6 bits	43	DVDD	Interface voltage
21	D25	Blue 5 bits	44	DVDD	Interface voltage
22	D24	Blue 4 bits	45	GND	
23	D23	Blue 3 bits			

### 3-6 USB

The USB interface built into EM1D is used to provide 1 channel of USB Host/Device/OTG function. The USB interface connector is a Mini-AB socket.

USB3329 (manufactured by SMSC) is used in the physical layer of USB.

<Connection diagram>

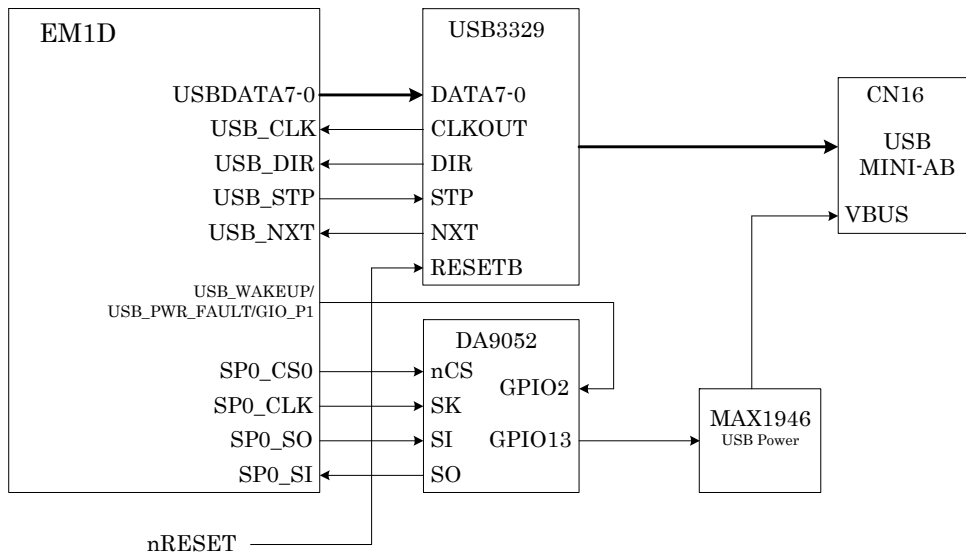

Used connector: 0565790519 (Manufactured by Molex)

Connector No.: CN16

Pin No.	Signal name	Remarks
1	VBUS	Power feeding (+5V)
2	D-	Data input/output signal (negated)
3	D+	Data input/output (positive)
4	ID	Device host detection
5	GND	Ground

Connector view

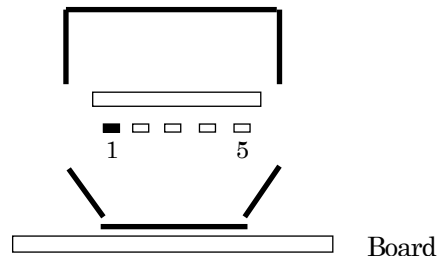

### 3-7 Micro SD Memory Card Interface

A socket for micro SD memory card to be connected to SD Memory Card Interface (SD0) built into EM1D is provided.

<Connection diagram>

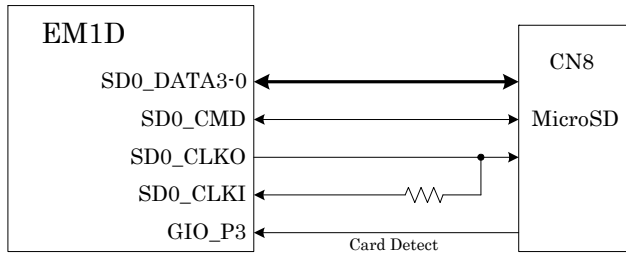

CN8 Used connector: DM3AT-SF-PEJ (manufactured by HIROSE ELECTRIC)

Connector No.: CN8

Pin No.	Signal name	Remarks
1	SD0_DATA2	Data
2	SD0_DATA3	Data
3	SD0_CMD	Command
4	VDD	Power
5	SD0_CKO	Clock output
6	GND	Ground
7	SD0_DATA0	Data
8	SD0_DATA1	Data
9	CD	Card detection
10	GND	Ground

### 3-8 eMMC NAND Flash Memory

4GB eMMC NAND flash memory is connected to SD Memory Card Interface (SD2) built into EM1D.

<Connection diagram>

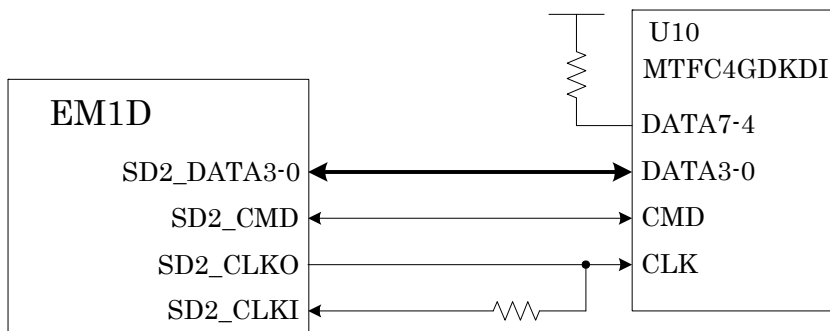

### 3-9 NOR Flash Memory

NOR flash memory is connected to AB0 built into EM1D.

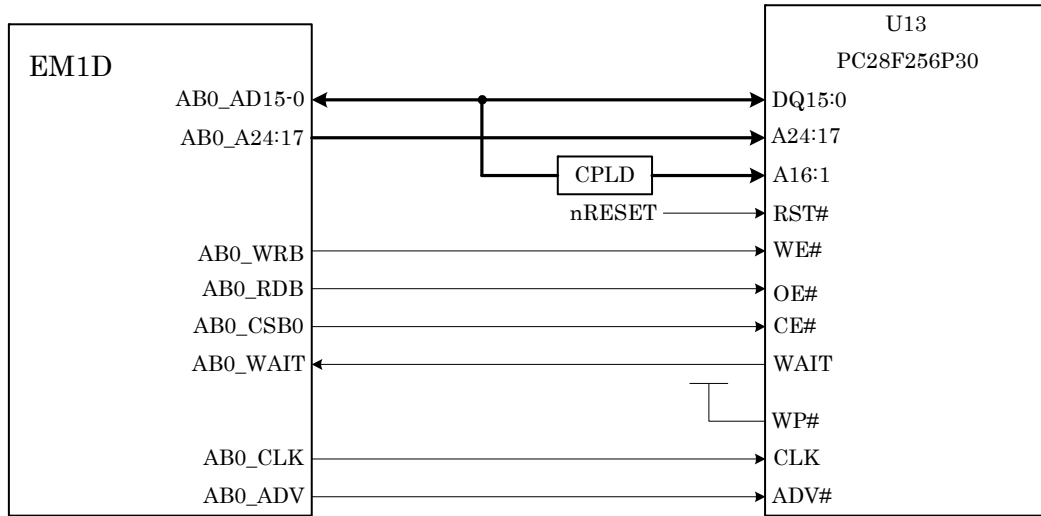

### 3-10 USB-UART

CP2103 is a USB to UART conversion chip. A host connected to CN17 mini-USB B connector can access it as a serial port. CP2103 has 4-bit GPIO, and by controlling this GPIO from a host, rebooting of EM1D or switching of boot devices can be performed.

<Connection diagram>

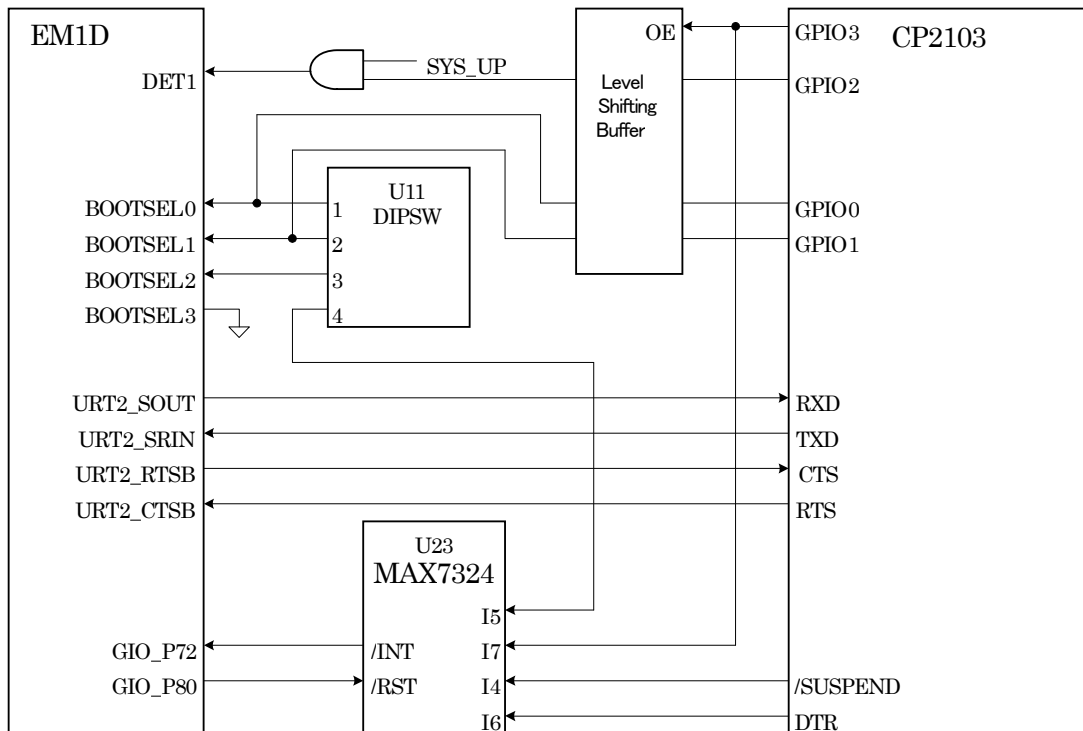

This USB port is provided mainly for the purpose of debugging and system diagnosis. This reference board cannot be operated by power fed from the USB host connected to CN17.

### 3-11 UART

UART0 and UART1, two channels of UART interface built into EM1D, are used.

They are converted to RS232 level signals on the board, and connected to a box-type 3 pin connector.

UART0 is connected to CN3 and UART1 to CN5.

Also, the route of RS232 I/F has a switch that enables input/output at the CMOS level using CN4.

<Connection diagram>

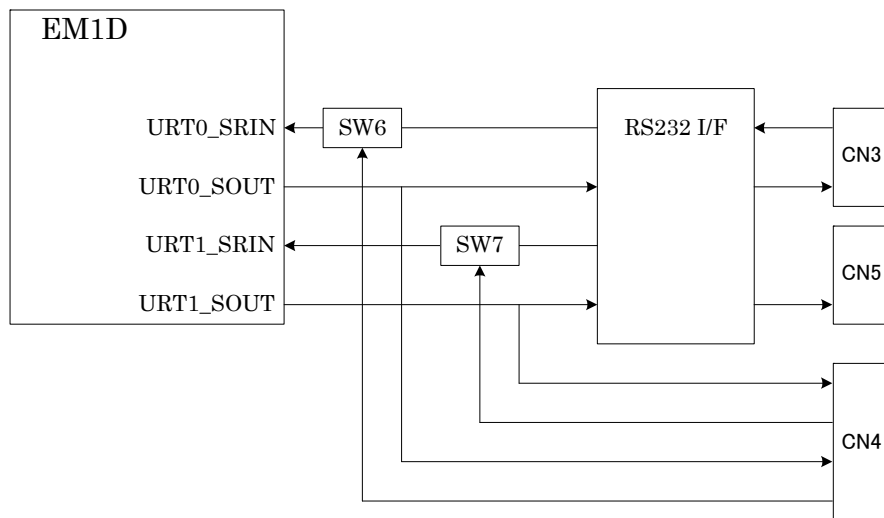

Used connector: B3B-PH-SM4-TB (manufactured by JST)

Connector No.: CN3, CN5

Pin No.	Signal name	Remarks
1	TXD	OUT
2	RXD	IN
3	GND	Ground

Connector view

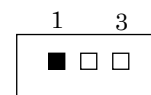



Used connector: B6B-PH-SM4-TB (manufactured by JST)

Connector No.: CN4

Pin No.	Signal name	Remarks
1	TX0	OUT0
2	RX0	IN0
3	GND	Ground
4	TX1	OUT1
5	RX1	IN1
6	VCC	Power supply +3.3V

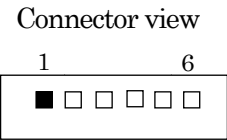

### 3-12 SOUND

Codec device ML7037-003 (manufactured by OKI SEMICONDUCTOR) that is connected to Audio/Voice Interface (PM0) built into EM1D is equipped. The initial setting to this device is performed using SP0 (SP0\_CS1) interface built into EM1D.

<Connection diagram>

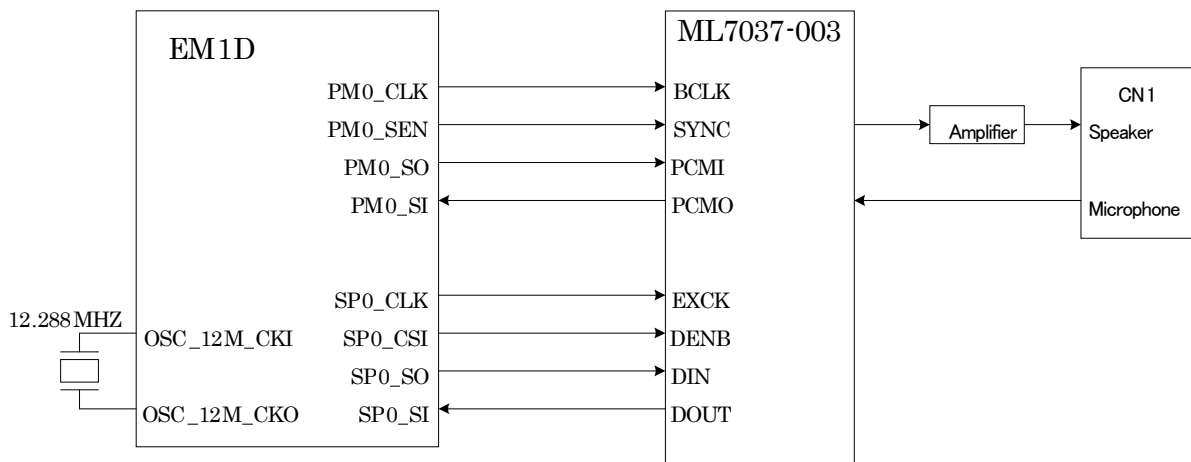

Used connector: B5B-PH-SM4-TB (manufactured by JST)

Connector No.: CN1

Terminal No.	Signal name	
1	VO1	Differential speaker output 1
2	VO2	Differential speaker output 2
3	GND	Ground (analogue line)
4	LINE_IN	Microphone input (power is fed inside the board)
5	AUDIO_V3	3.3V power output (analogue line)

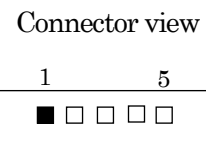

The speaker output is the amplifier output of 1.1W (8ohm). VOL1 on the board can adjust the audio volume. As the speaker output signals are differential, pay attention not to connect either one of them to GND such as the chassis.

### 3-13 High Speed Link System (HLS)

HLS is a 2-wire interface in 1:N communication used for FA or semiconductor production devices.

Refer to <http://www.steptecnica.com/hls/index.html>, etc.

HLS is connected via CPLD for converting and controlling the signal level to AB0 of EM1D.

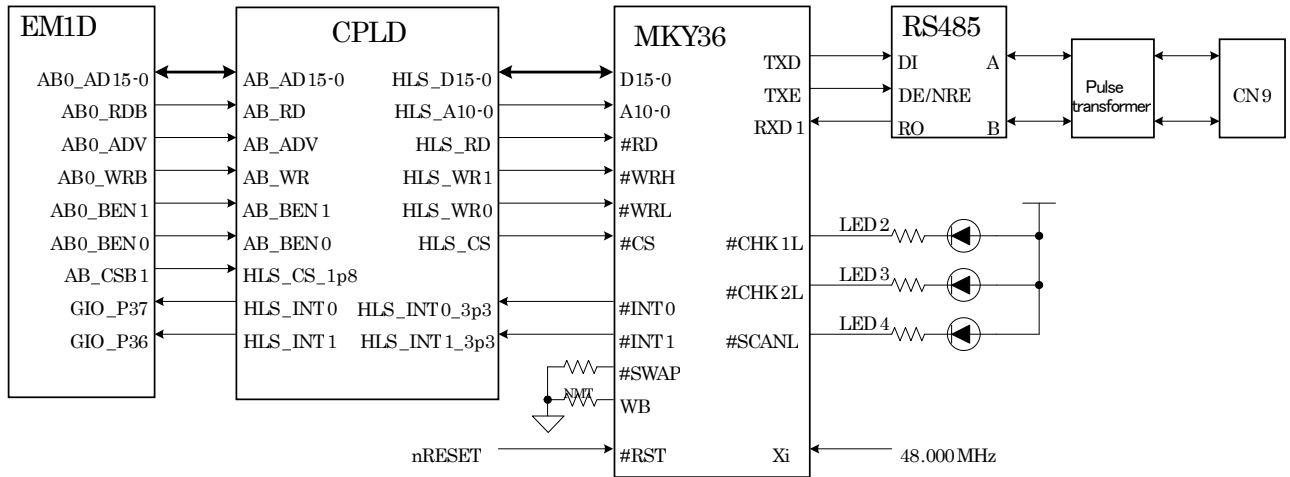

Used Connector: S3B-XH-SM4-TB

Connector No.: CN9

### 3-14 LED

Four general-purpose LEDs are provided. They are connected to Port 08-011 of the GPIO expansion chip connected to IIC2.

LED is turned off with the logic level '1,' and turned on with '0.'

\*In the initial state, all the LED lights are turned on.

<Connection diagram>

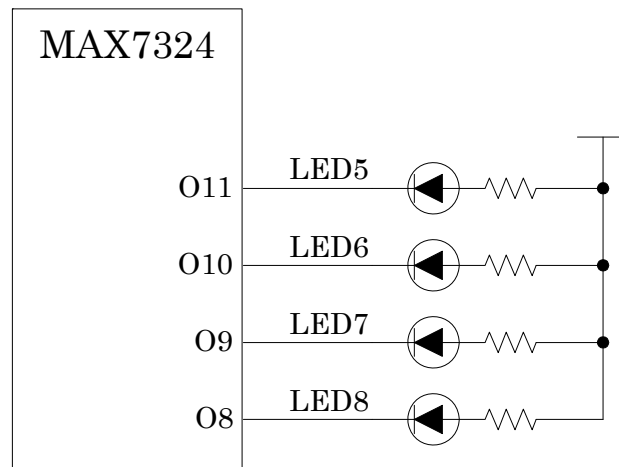

### 3-15 Isolated Input/Output

The I/O ports isolated by photo coupler are provided for 4-bit input and 4-bit output.  
 The photo coupler is connected to the port of the GPIO extension chip connected to IIC2.  
 \*In the initial state, 4-bit output is off.

<Connection diagram>

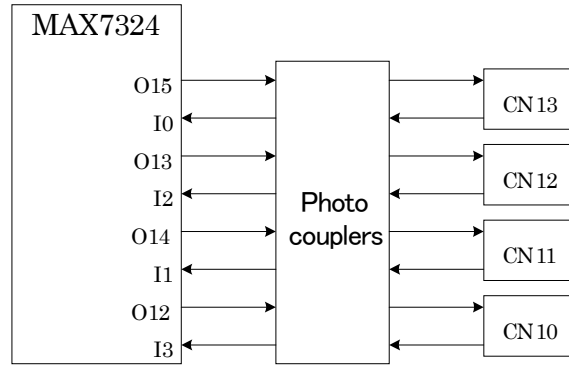

Used connector: B4B-PH-SM4-TB  
 Connector No.: CN10, CN11, CN12, CN13

Pin No.	Signal name
1	Output collector
2	Output emitter
3	Input anode
4	Input cathode

Connector view

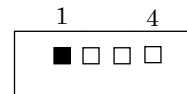

### 3-16 Camera Interface

The interface in YUV422 format built in EM1D is used.  
 For module control, IIC2 is used.  
 Compatible camera: NCM03-V (manufactured by Asahi Electronics Laboratory), VGA resolution

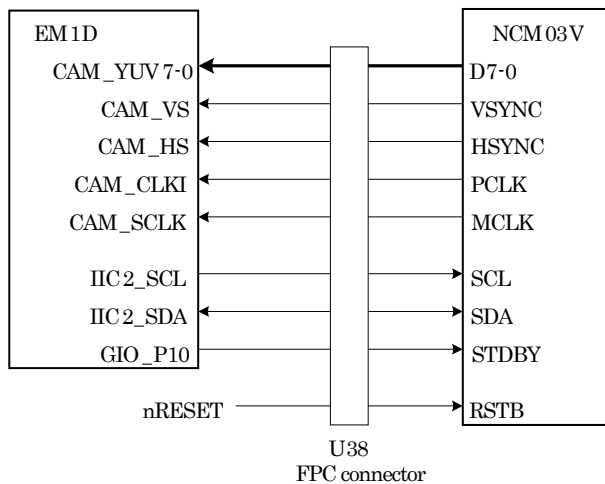

### 3-17 Illuminance Sensor

The illuminance sensor is connected to IIC2 of EM1D.

Used sensor: BH1710FVC (manufactured by ROHM), 16-bit resolution

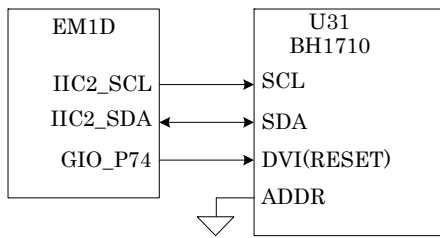

### 3-18 Temperature Sensor

The temperature sensor is connected to SP2 of EM1D.

Used sensor: AD7814ARMZ (manufactured by AD), 10-bit resolution

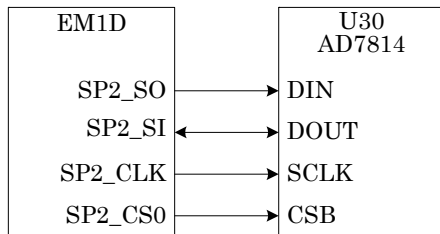

Note: SPI and IIC are accessible from outside via CN14. (SPI is exclusive to the temperature sensor.)

### 3-19 JTAG

Debugging of ARM CPU and DSP is possible using the debug interface built into EM1D.

The target of debugging is switched by SW8. To activate or deactivate debugging, set SW9.

PARTNER-Jet (manufactured by Kyoto Microcomputer) can be connected.

Used connector: 2-5767004-2 (manufactured by Tyco AMP)

Connector No.: CN7

Pin No.	Signal name	Remarks
1	NC1	OPEN
2	NC2	OPEN
3	NC3	OPEN
4	NC4	OPEN
5	GND	
6	TRACECLK	PD
7	DBGRRQ	OPEN
8	DBGACK	PD
9	NSRST	EM1D
10	EXTTRIG	PU
11	TDO	EM1D
12	VREF	2.85V
13	RTCK	EM1D
14	VCC	
15	TCK	EM1D
16	TRACEPKT7	PD
17	TMS	EM1D
18	TRACEPKT6	PD
19	TDI	EM1D
20	TRACEPKT5	PD
21	NTRST	EM1D
22	TRACEPKT4	PD
23	TRACEPKT15	PD
24	TRACEPKT3	PD
25	TRACEPKT14	PD
26	TRACEPKT2	PD
27	TRACEPKT13	PD
28	TRACEPKT1	PD
29	TRACEPKT12	PD
30	TRACEPKT0	PD
31	TRACEPKT11	PD
32	TRACESYNC	PD
33	TRACEPKT10	PD
34	PIPESTAT2	PD
35	TRACEPKT9	PD
36	PIPESTAT1	PD
37	TRACEPKT8	PD
38	PIPESTAT0	PD

### 3-20 Switch

Push button switches are connected to ports of EM1D, GIO\_P8, GIO\_P7, GIO\_P6 and GIO\_P4.

The logic is “1” when the switch is pushed down, and it is “0” when the switch is released.

SW1 is connected to GIO\_P8, SW2 to GIO\_P7, SW3 to GIO\_P6, and SW4 to GIO\_P4.

<Connection diagram>

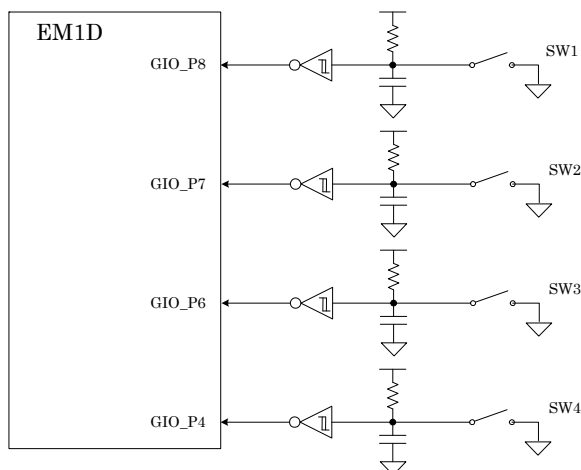

## 4 GPIO Connection and Setting

### GPIO Connection

Terminal name	Direction	Connection destination	Connection terminal	Active level	Remarks
GIO_P81	IN	LAN9221	PME		WOL input (Backup)
GIO_P9	OUT	ML7037	nPDN	0	Power down
GIO_P2	OUT	ML7037	nRST	0	Reset
GIO_P73	OUT	LM4876	nSHUTDOWN	0	Power down
GIO_P94	IN	RX-4581	/TIRQ	0	Timer interrupt
GIO_P95	IN	RX-4581	/AIRQ	0	Time interrupt
GIO_P72	IN	MAX7324	nINT	0	Interrupt
GIO_P82	OUT	UF-801006A	DISP	1	LCD ON (1) · OFF (0)
GIO_P10	OUT	NCV03-V	STDBY	1	Color module/Standby
GIO_P3	IN	DM3AT-SF-PEJ	A	0	SD detected (0) · undetected (1)

### Shared Pin Switch

Abbreviated name	Register name	Address	Value	Remarks
CHG_PINSEL_G00	GIO_P[15:0] shared port switch register	C014_0200H	5540_0C00H	
CHG_PINSEL_G16	GIO_P[31:16] shared port switch register	C014_0204H	5555_5555H	
CHG_PINSEL_G32	GIO_P[47:32] shared port switch register	C014_0208H	5455_5055H	
CHG_PINSEL_G48	GIO_P[63:48] shared port switch register	C014_020CH	5555_5555H	
CHG_PINSEL_G64	GIO_P[79:64] shared port switch register	C014_0210H	FFC0_5555H	
CHG_PINSEL_G80	GIO_P[95:80] shared port switch register	C014_0214H	0655_6955H	
CHG_PINSEL_G96	GIO_P[111:96] shared port switch register	C014_0218H	5555_5555H	
CHG_PINSEL_G112	GIO_P[117:112] shared port switch register	C014_021CH	0000_0555H	
CHG_PINSEL_SP0	SP0 shared port switch register	C014_0280H	0000_0000H	
CHG_PINSEL_DTV	DTV shared port switch register	C014_0284H	0000_0001H	
CHG_PINSEL_SD0	SD0 shared port switch register	C014_0288H	0000_0000H	
CHG_PINSEL_SD1	SD1 shared port switch register	C014_028CH	0000_0002H	
CHG_PINSEL_IIC2	IIC2 shared port switch register	C014_0290H	0000_0000H	

## 5 ABO Address Allocation

## Address Map Setting

Abbreviated name	Register name	Address	Value	Remarks
AB0_CS0BASEADD	Base address register for CS0	2FFF_0100H	0000_0000H	NOR
AB0_CS0BITCOMP	Bit compare register for CS0	2FFF_0104H	FF00_0000H	
AB0_CS1BASEADD	Base address register for CS1	2FFF_0110H	1000_0000H	HLS
AB0_CS1BITCOMP	Bit compare register for CS1	2FFF_0114H	FFFF_FC00H	
AB0_CS2BASEADD	Base address register for CS2	2FFF_0120H	1100_0000H	NC
AB0_CS2BITCOMP	Bit compare register for CS2	2FFF_0124H	FF00_0000H	
AB0_CS3BASEADD	Base address register for CS3	2FFF_0130H	2000_0000H	LAN
AB0_CS3BITCOMP	Bit compare register for CS3	2FFF_0134H	FFFF_F800H	

### 6 Memory Map

The following is the memory map of this reference board.

External Memory Interface (AB0) is connected to NOR FLASH, HLS and Ethernet controller, and Memory Interface (MEMC) to the built-in DDRSDRAM.

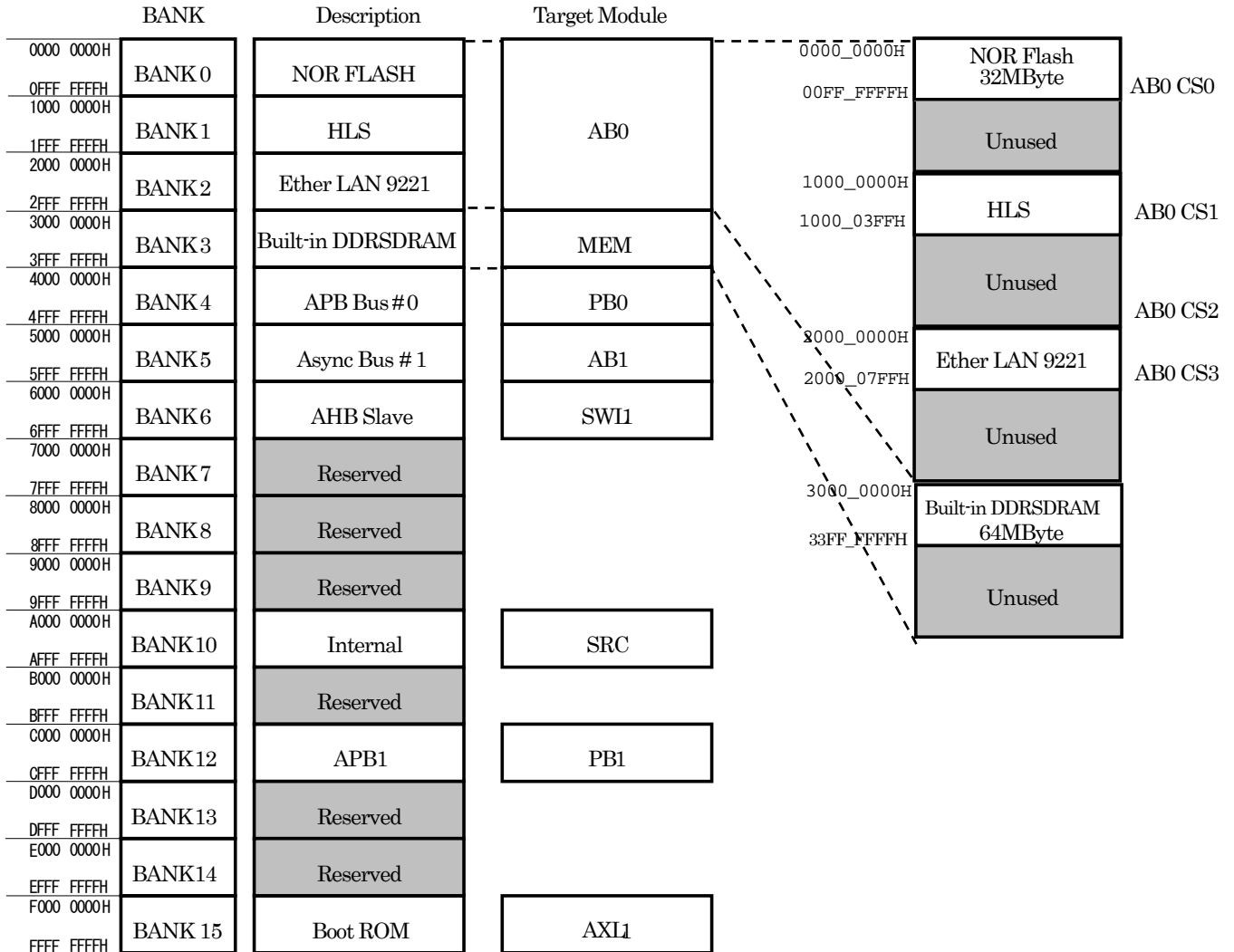



7 External View of Board

7-1 Parts Side

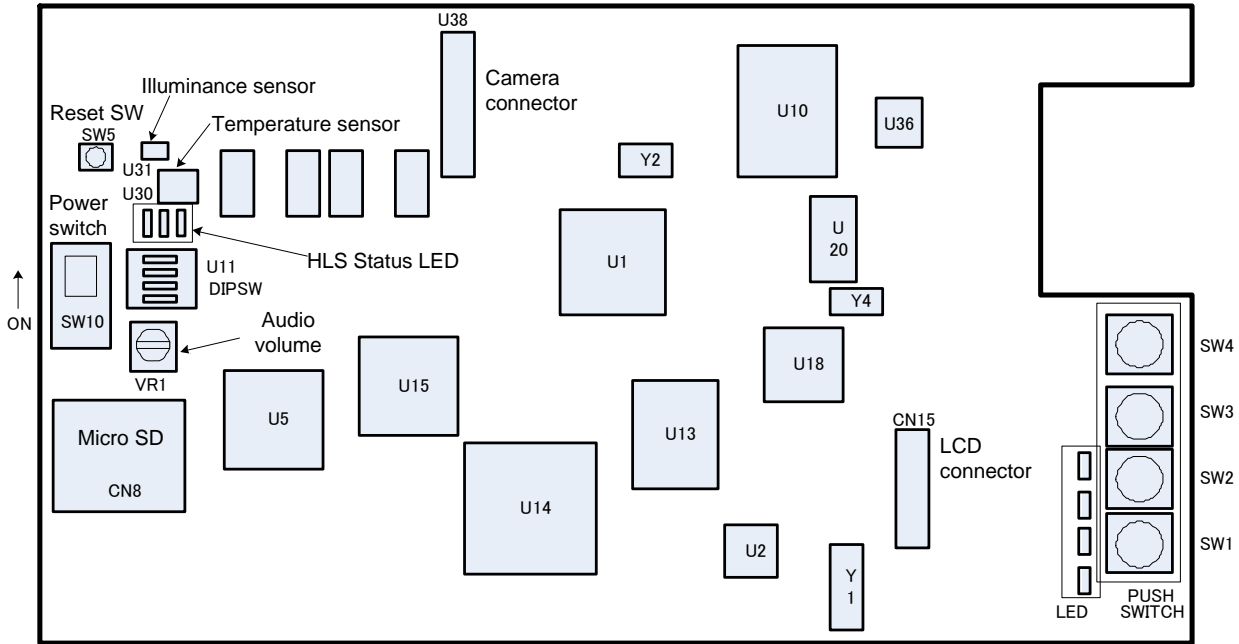

7-2 Connector Position on Solder Side

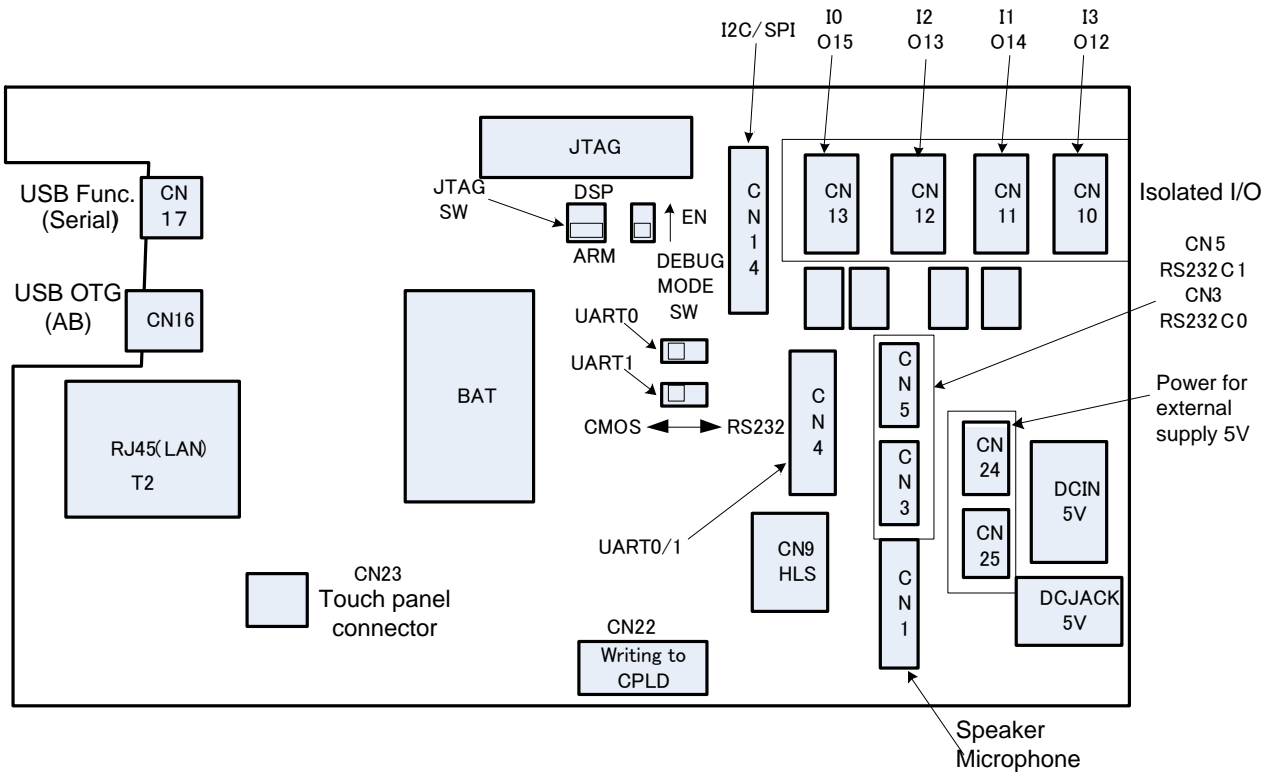

## 8 Circuit Diagram





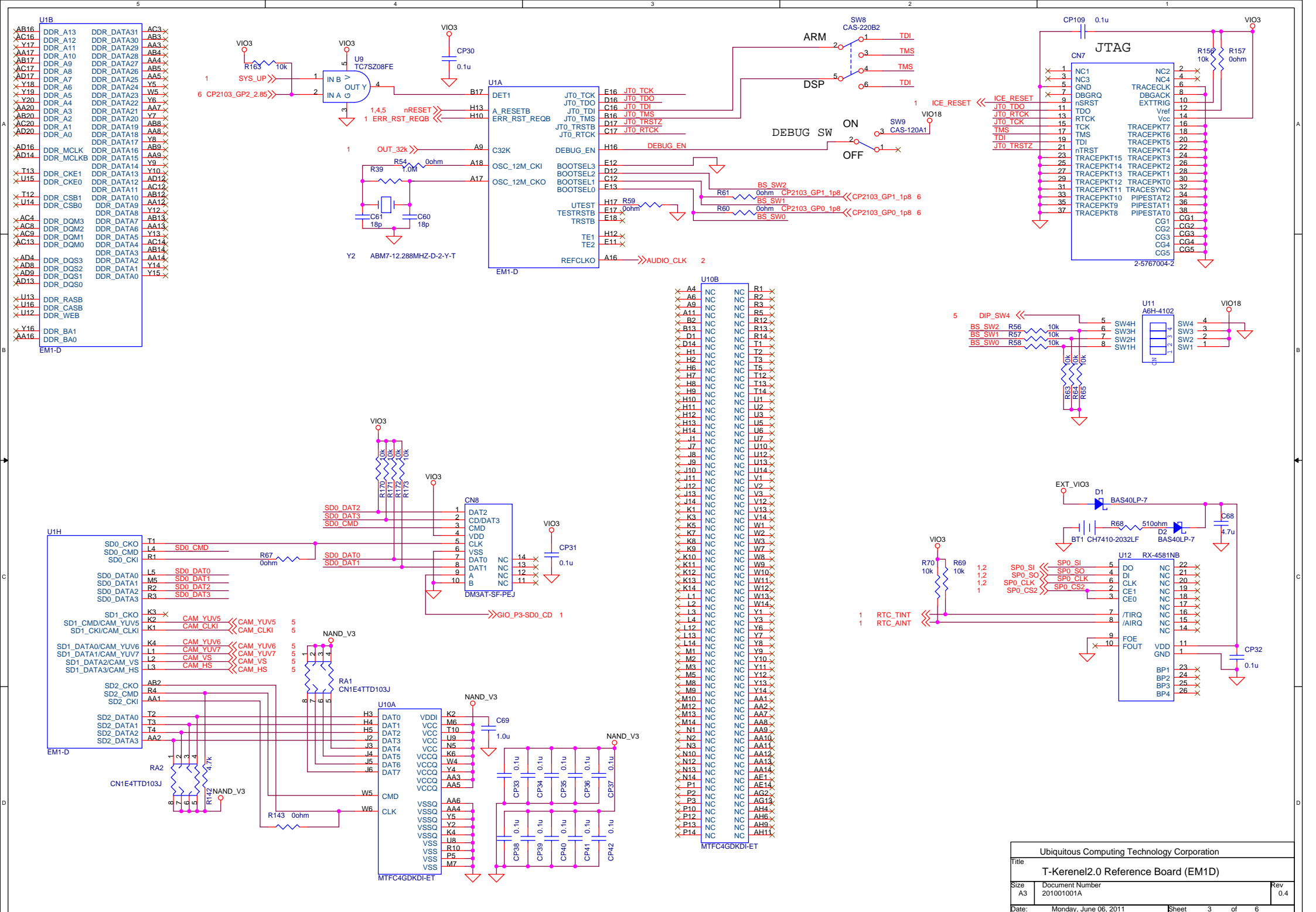

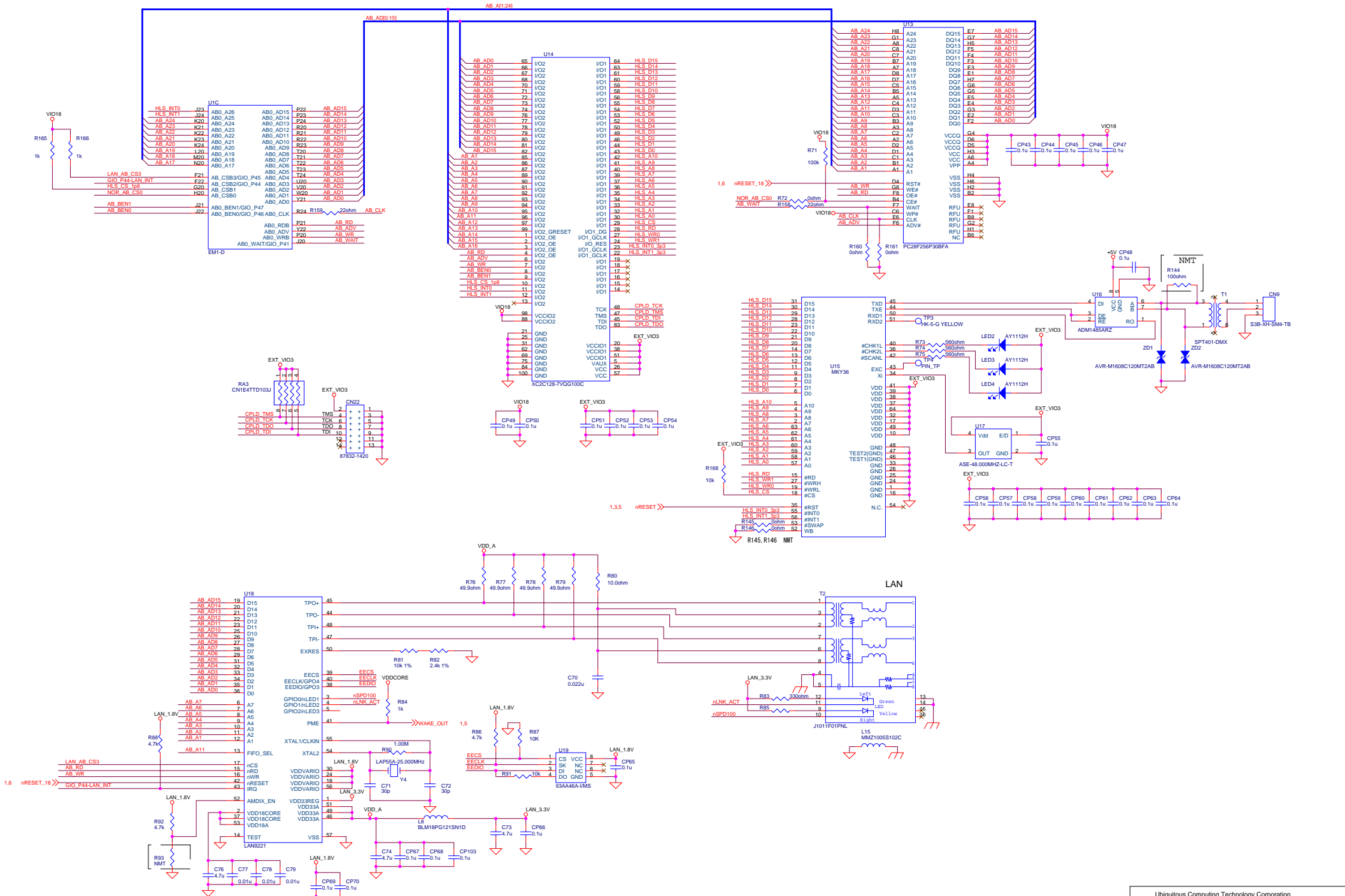

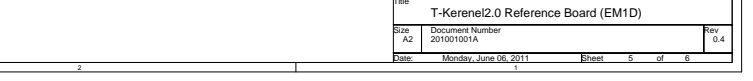
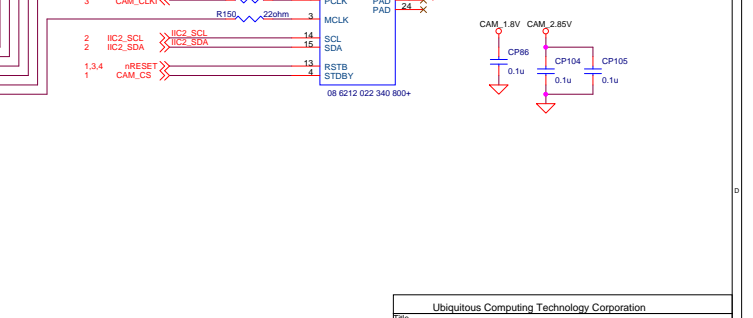
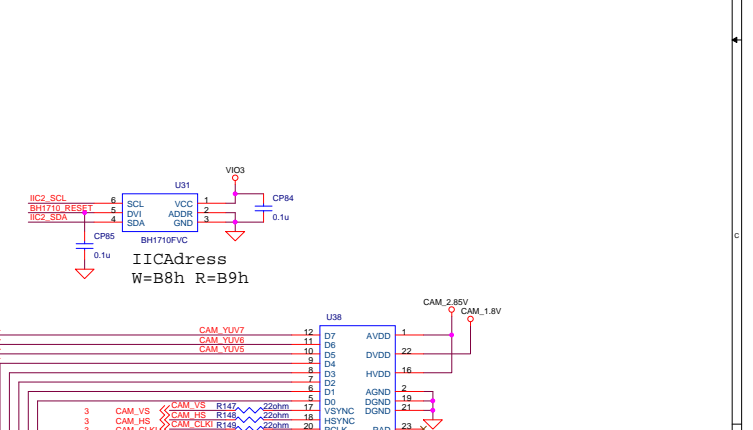
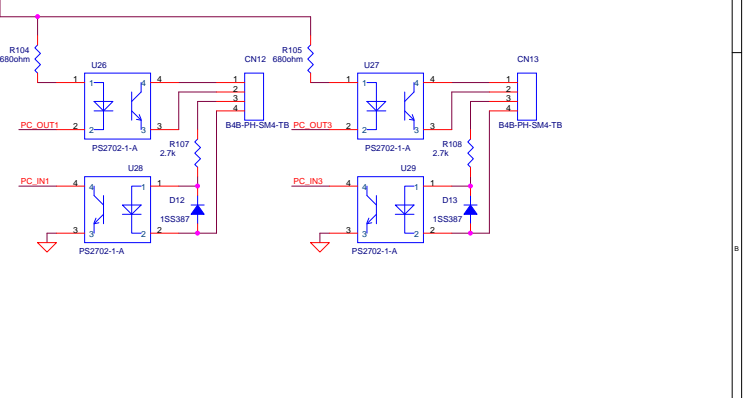
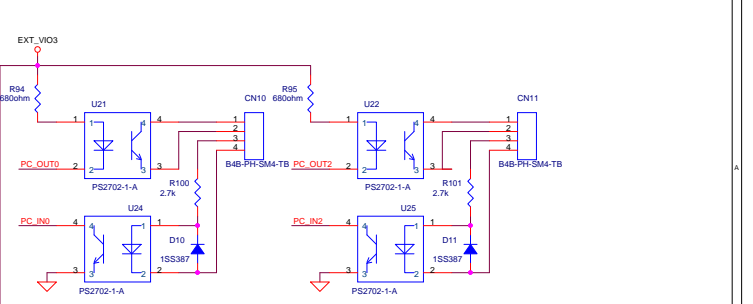
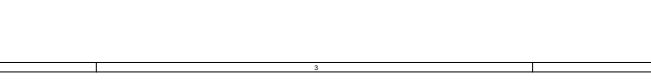
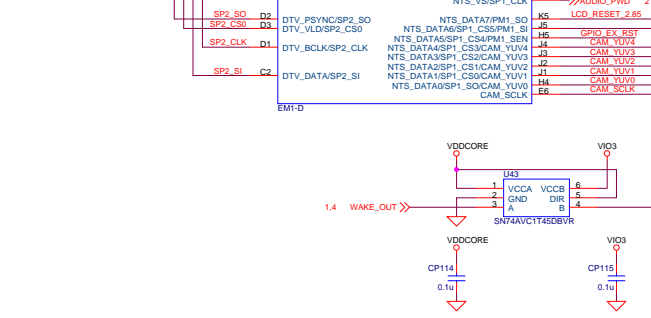
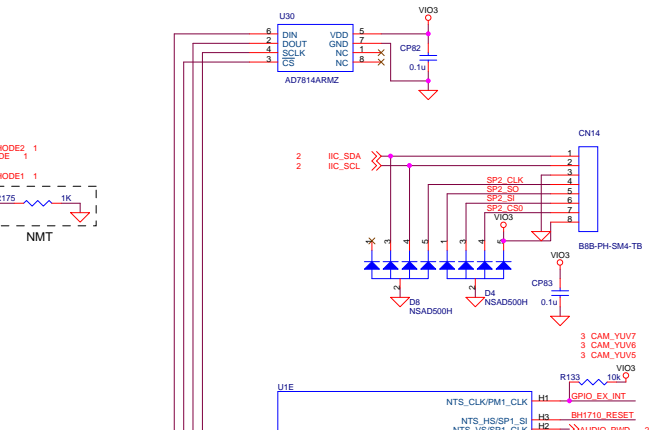
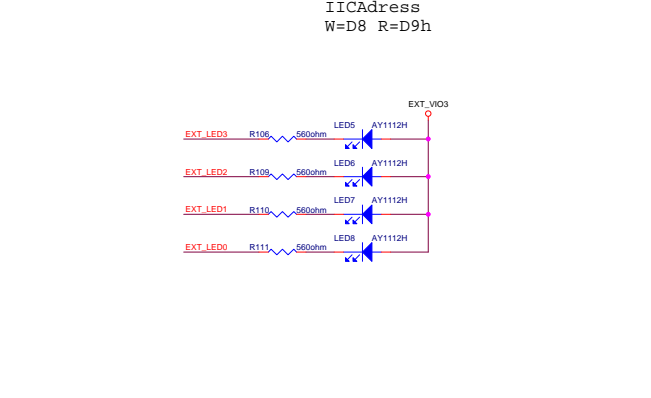
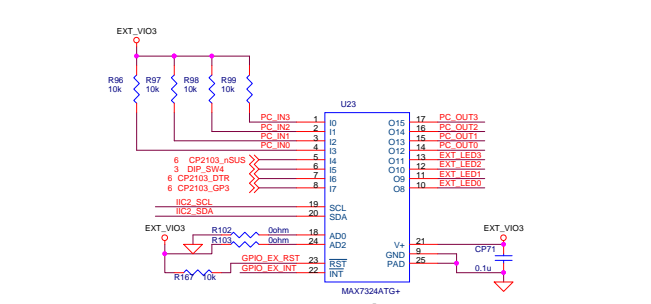
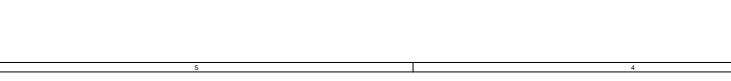
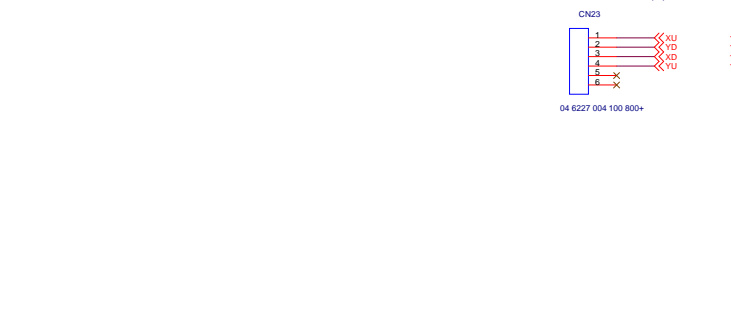
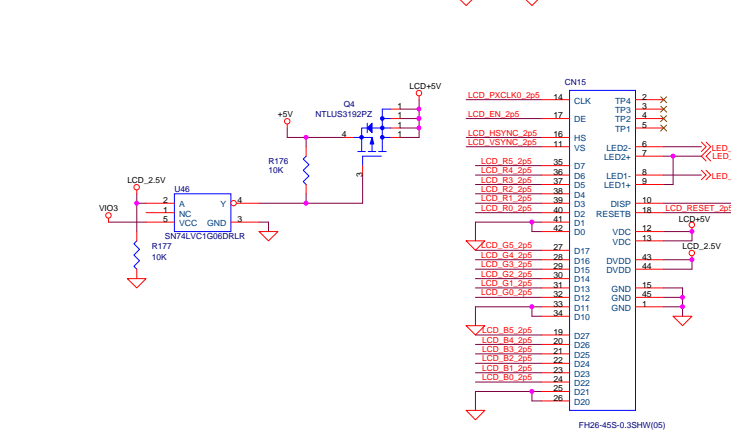
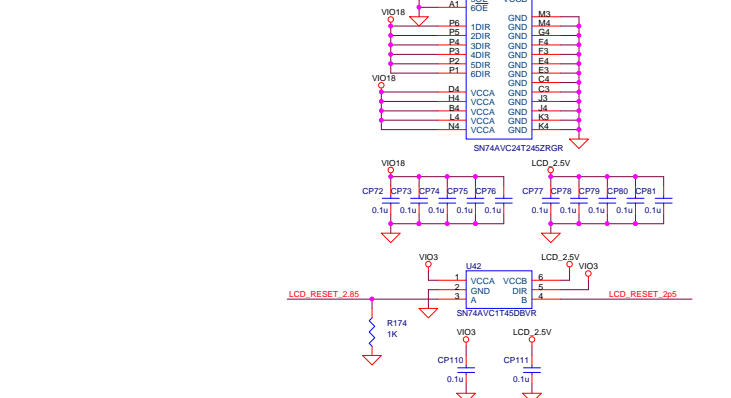
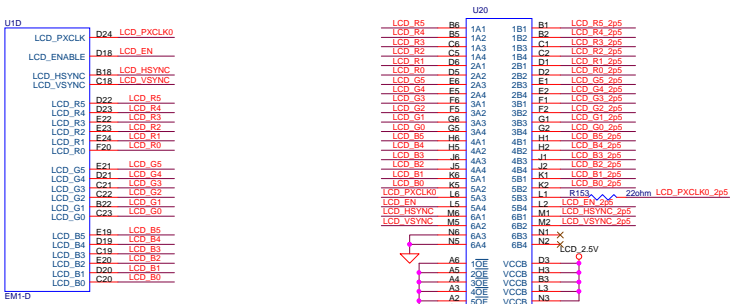

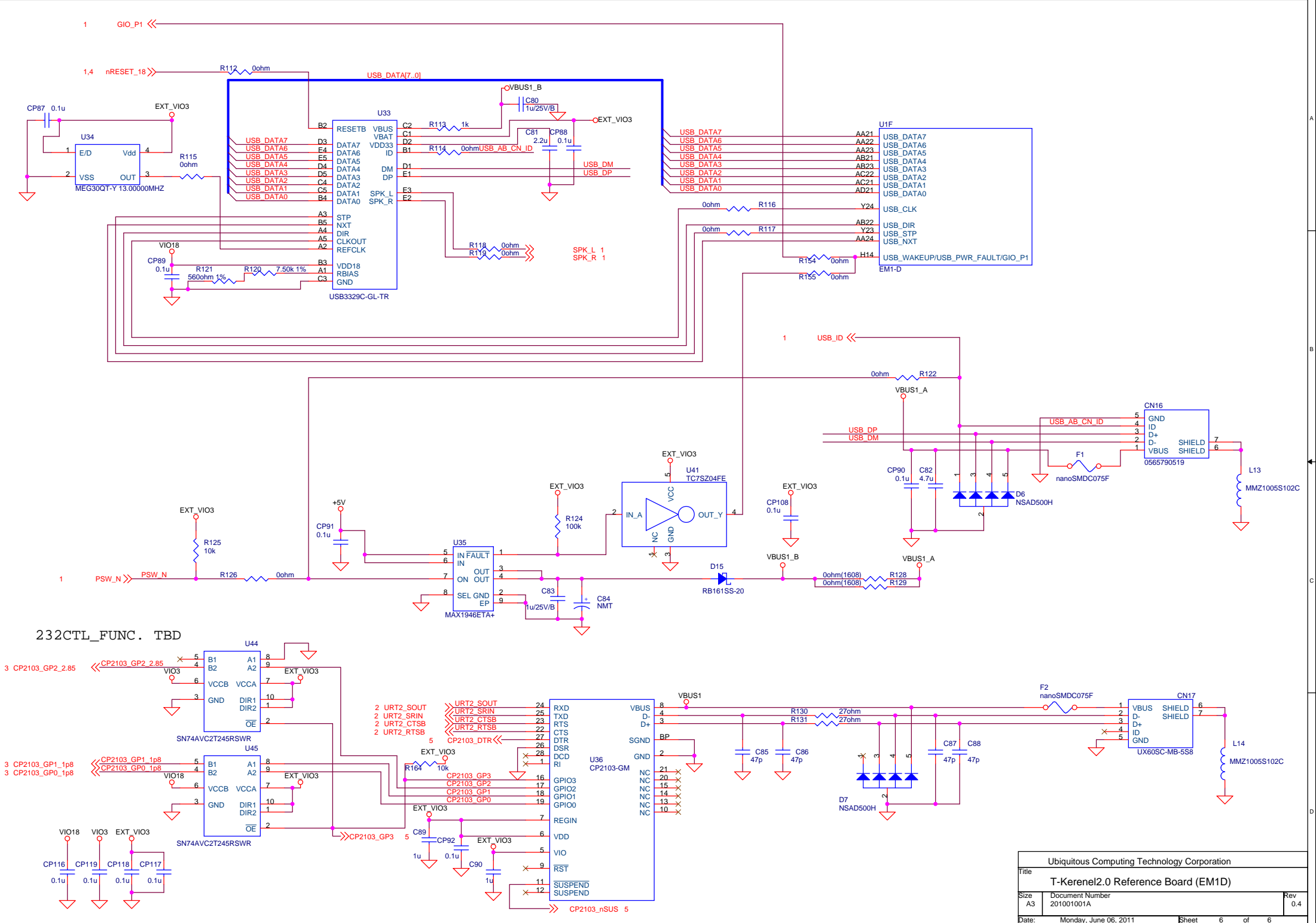

232CTL\_FUNC . TBD

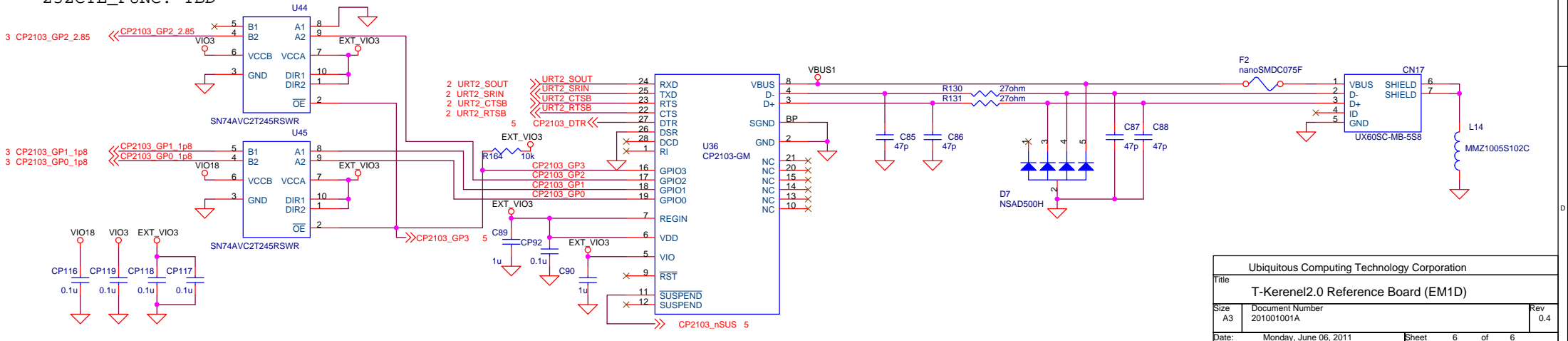

Ubiquitous Computing Technology Corporation		
Title	T-Kernel2.0 Reference Board (EM1D)	
Size	Document Number	Rev
A3	201001001A	0.4
Date:	Monday, June 06, 2011	Sheet 6 of 6